

# **PHILIPPINE BIDDING DOCUMENTS**

## ***Re-bid: Concreting of Block Roads at P-1 Public Market***

**PID NO. 2022 – 075-A**

Government of the Republic of the Philippines

**Sixth Edition  
July 2020**

# TABLE OF CONTENTS

<b>Glossary of Terms, Abbreviations, and Acronyms .....</b>	<b>4</b>
<b>Section I. Invitation to Bid.....</b>	<b>7</b>
<b>Section II. Instructions to Bidders .....</b>	<b>10</b>
1. Scope of Bid.....	11
2. Funding Information .....	11
3. Bidding Requirements.....	11
4. Corrupt, Fraudulent, Collusive, Coercive, and Obstructive Practices .....	11
5. Eligible Bidders.....	12
6. Origin of Associated Goods .....	12
7. Subcontracts .....	12
8. Pre-Bid Conference.....	12
9. Clarification and Amendment of Bidding Documents.....	13
10. Documents Comprising the Bid: Eligibility and Technical Components ...	13
11. Documents Comprising the Bid: Financial Component .....	13
12. Alternative Bids .....	14
13. Bid Prices .....	14
14. Bid and Payment Currencies.....	14
15. Bid Security.....	14
16. Sealing and Marking of Bids.....	14
17. Deadline for Submission of Bids .....	15
18. Opening and Preliminary Examination of Bids .....	15
19. Detailed Evaluation and Comparison of Bids.....	15
20. Post Qualification.....	15
21. Signing of the Contract .....	16
<b>Section III. Bid Data Sheet .....</b>	<b>17</b>
<b>Section IV. General Conditions of Contract.....</b>	<b>20</b>
1. Scope of Contract.....	21
2. Sectional Completion of Works .....	21
3. Possession of Site .....	21
4. The Contractor's Obligations.....	21
5. Performance Security .....	22
6. Site Investigation Reports .....	22

7.	Warranty.....	22
8.	Liability of the Contractor.....	22
9.	Termination for Other Causes.....	22
10.	Dayworks .....	22
11.	Program of Work.....	23
12.	Instructions, Inspections and Audits .....	23
13.	Advance Payment.....	23
14.	Progress Payments .....	23
15.	Operating and Maintenance Manuals.....	23
	<b>Section V. Special Conditions of Contract.....</b>	<b>25</b>
	<b>Section VI. Specifications .....</b>	<b>27</b>
	<b>Section VII. Drawings.....</b>	<b>130</b>
	<b>Section VIII. Bill of Quantities .....</b>	<b>137</b>
	<b>Section IX. Checklist of Technical and Financial Documents .....</b>	<b>138</b>

# *Glossary of Terms, Abbreviations, and Acronyms*

**ABC** – Approved Budget for the Contract.

**ARCC** – Allowable Range of Contract Cost.

**BAC** – Bids and Awards Committee.

**Bid** – A signed offer or proposal to undertake a contract submitted by a bidder in response to and in consonance with the requirements of the bidding documents. Also referred to as *Proposal* and *Tender*. (2016 revised IRR, Section 5[c])

**Bidder** – Refers to a contractor, manufacturer, supplier, distributor and/or consultant who submits a bid in response to the requirements of the Bidding Documents. (2016 revised IRR, Section 5[d])

**Bidding Documents** – The documents issued by the Procuring Entity as the bases for bids, furnishing all information necessary for a prospective bidder to prepare a bid for the Goods, Infrastructure Projects, and/or Consulting Services required by the Procuring Entity. (2016 revised IRR, Section 5[e])

**BIR** – Bureau of Internal Revenue.

**BSP** – Bangko Sentral ng Pilipinas.

**CDA** – Cooperative Development Authority.

**Consulting Services** – Refer to services for Infrastructure Projects and other types of projects or activities of the GOP requiring adequate external technical and professional expertise that are beyond the capability and/or capacity of the GOP to undertake such as, but not limited to: (i) advisory and review services; (ii) pre-investment or feasibility studies; (iii) design; (iv) construction supervision; (v) management and related services; and (vi) other technical services or special studies. (2016 revised IRR, Section 5[i])

**Contract** – Refers to the agreement entered into between the Procuring Entity and the Supplier or Manufacturer or Distributor or Service Provider for procurement of Goods and Services; Contractor for Procurement of Infrastructure Projects; or Consultant or Consulting Firm for Procurement of Consulting Services; as the case may be, as recorded in the Contract Form signed by the parties, including all attachments and appendices thereto and all documents incorporated by reference therein.

**Contractor** – is a natural or juridical entity whose proposal was accepted by the Procuring Entity and to whom the Contract to execute the Work was awarded. Contractor as used in these Bidding Documents may likewise refer to a supplier, distributor, manufacturer, or consultant.

**CPI** – Consumer Price Index.

**DOLE** – Department of Labor and Employment.

**DTI** – Department of Trade and Industry.

**Foreign-funded Procurement or Foreign-Assisted Project** – Refers to procurement whose funding source is from a foreign government, foreign or international financing institution as specified in the Treaty or International or Executive Agreement. (2016 revised IRR, Section 5[b]).

**GFI** – Government Financial Institution.

**GOCC** – Government-owned and/or –controlled corporation.

**Goods** – Refer to all items, supplies, materials and general support services, except Consulting Services and Infrastructure Projects, which may be needed in the transaction of public businesses or in the pursuit of any government undertaking, project or activity, whether in the nature of equipment, furniture, stationery, materials for construction, or personal property of any kind, including non-personal or contractual services such as the repair and maintenance of equipment and furniture, as well as trucking, hauling, janitorial, security, and related or analogous services, as well as procurement of materials and supplies provided by the Procuring Entity for such services. The term “related” or “analogous services” shall include, but is not limited to, lease or purchase of office space, media advertisements, health maintenance services, and other services essential to the operation of the Procuring Entity. (2016 revised IRR, Section 5[r])

**GOP** – Government of the Philippines.

**Infrastructure Projects** – Include the construction, improvement, rehabilitation, demolition, repair, restoration or maintenance of roads and bridges, railways, airports, seaports, communication facilities, civil works components of information technology projects, irrigation, flood control and drainage, water supply, sanitation, sewerage and solid waste management systems, shore protection, energy/power and electrification facilities, national buildings, school buildings, hospital buildings, and other related construction projects of the government. Also referred to as *civil works or works*. (2016 revised IRR, Section 5[u])

**LGUs** – Local Government Units.

**NFCC** – Net Financial Contracting Capacity.

**NGA** – National Government Agency.

**PCAB** – Philippine Contractors Accreditation Board.

**PhilGEPS** - Philippine Government Electronic Procurement System.

**Procurement Project** – refers to a specific or identified procurement covering goods, infrastructure project or consulting services. A Procurement Project shall be described, detailed, and scheduled in the Project Procurement Management Plan prepared by the agency which shall be consolidated in the procuring entity's Annual Procurement Plan. (GPPB Circular No. 06-2019 dated 17 July 2019)

**PSA** – Philippine Statistics Authority.

**SEC** – Securities and Exchange Commission.

**SLCC** – Single Largest Completed Contract.

**UN** – United Nations.

***Section I. Invitation to Bid***



Republic of the Philippines  
Province of Davao de Oro  
**MUNICIPALITY OF COMPOSTELA**  
**BIDS AND AWARDS COMMITTEE**  
CP#: 0909-279-9827



## **Invitation to Bid for *Re-bid: Concreting of Block Roads at P-1 Public Market***

1. The *Municipality of Compostela*, through the *Supplemental Budget (General Fund)* intends to apply the sum of *One Million Five Hundred Thousand Pesos Only (P1,500,000.00)* being the Approved Budget for the Contract (ABC) to payments under the contract for *Re-bid: Concreting of Block Roads at P-1 Public Market with Project Identification No. 2022-075-A*. Bids received in excess of the ABC shall be automatically rejected at bid opening.
2. The Municipality of Compostela now invites bids for the above Procurement Project. Completion of the Works is required *90 calendar days*. Bidders should have completed a contract similar to the Project. The description of an eligible bidder is contained in the Bidding Documents, particularly, in Section II (Instructions to Bidders).
3. Bidding will be conducted through open competitive bidding procedures using non-discretionary “*pass/fail*” criterion as specified in the 2016 revised Implementing Rules and Regulations (IRR) of Republic Act (RA) No. 9184.
4. Interested bidders may obtain further information from Municipality of Compostela and inspect the Bidding Documents at the address given below from *8:00 a.m. to 5:00 p.m.*
5. A complete set of Bidding Documents may be acquired by interested bidders on ***August 22, 2022 to September 13, 2022*** from given address and website below *upon payment of the applicable fee for the Bidding Documents, pursuant to the latest Guidelines issued by the GPPB, in the amount of Five Thousand Pesos (P5,000.00)*. The Procuring Entity shall allow the bidder to present its proof of payment for the fees ***presented in person***.
6. The Municipality of Compostela will hold a Pre-Bid Conference on ***August 30, 2022 at 1:30 p.m.*** at Office of the BAC, 2<sup>nd</sup> Floor, Municipal Hall Building, Dagohoy St., Purok 2, Poblacion, Compostela, Davao de Oro which shall be open to prospective bidders.
7. Bids must be duly received by the BAC Secretariat through manual submission at the office address as indicated below on ***September 13, 2022 at 1:00 p.m.*** Late bids shall not be accepted.



8. All bids must be accompanied by a bid security in any of the acceptable forms and in the amount stated in **ITB** Clause 16.
9. Bid opening shall be on **September 13, 2022 at 1:30 p.m.** at the given address below. Bids will be opened in the presence of the bidders' representatives who choose to attend the activity.
10. The *Municipality of Compostela* reserves the right to reject any and all bids, declare a failure of bidding, or not award the contract at any time prior to contract award in accordance with Sections 35.6 and 41 of the 2016 revised Implementing Rules and Regulations (IRR) of RA No. 9184, without thereby incurring any liability to the affected bidder or bidders.
11. For further information, please refer to:  
  
**EDWARD FORD N. DAGATAN**  
BAC Office  
2<sup>nd</sup> Floor, Municipal Hall Building, Dagohoy St., Purok 2,  
Poblacion, Compostela, Davao de Oro  
CP#: 0909-279-9827  
Email Add: compobacsec@gmail.com
12. You may visit [www.philgeps.gov.ph](http://www.philgeps.gov.ph) and search for Municipality of Compostela for downloading of Bidding Documents.

*August 22, 2022*

(Sgd.)  
**LUCELIA L. PAQUEO**  
BAC Chairperson

## ***Section II. Instructions to Bidders***

## **1. Scope of Bid**

The Procuring Entity, *Municipality of Compostela*, invites Bids for the *Re-bid: Concreting of Block Roads at P-1 Public Market* with Project Identification Number 2022-075-A.

*[Note: The Project Identification Number is assigned by the Procuring Entity based on its own coding scheme and is not the same as the PhilGEPS reference number, which is generated after the posting of the bid opportunity on the PhilGEPS website.]*

The Procurement Project (referred to herein as “Project”) is for the construction of Works, as described in Section VI (Specifications).

## **2. Funding Information**

2.1. The GOP through the source of funding as indicated below for *CY 2022* in the amount of *One Million Five Hundred Thousand Pesos Only (P1,500,000.00)*.

2.2. The source of funding is: LGUs, the Supplemental Budget, as approved by the Sanggunian.

## **3. Bidding Requirements**

The Bidding for the Project shall be governed by all the provisions of RA No. 9184 and its 2016 revised IRR, including its Generic Procurement Manual and associated policies, rules and regulations as the primary source thereof, while the herein clauses shall serve as the secondary source thereof.

Any amendments made to the IRR and other GPPB issuances shall be applicable only to the ongoing posting, advertisement, or invitation to bid by the BAC through the issuance of a supplemental or bid bulletin.

The Bidder, by the act of submitting its Bid, shall be deemed to have inspected the site, determined the general characteristics of the contracted Works and the conditions for this Project, such as the location and the nature of the work; (b) climatic conditions; (c) transportation facilities; (c) nature and condition of the terrain, geological conditions at the site communication facilities, requirements, location and availability of construction aggregates and other materials, labor, water, electric power and access roads; and (d) other factors that may affect the cost, duration and execution or implementation of the contract, project, or work and examine all instructions, forms, terms, and project requirements in the Bidding Documents.

## **4. Corrupt, Fraudulent, Collusive, Coercive, and Obstructive Practices**

The Procuring Entity, as well as the Bidders and Contractors, shall observe the highest standard of ethics during the procurement and execution of the contract. They or through an agent shall not engage in corrupt, fraudulent, collusive, coercive, and obstructive practices defined under Annex “I” of the 2016 revised IRR of RA No. 9184 or other integrity violations in competing for the Project.

## 5. Eligible Bidders

- 5.1. Only Bids of Bidders found to be legally, technically, and financially capable will be evaluated.
- 5.2. The Bidder must have an experience of having completed a Single Largest Completed Contract (SLCC) that is similar to this Project, equivalent to at least fifty percent (50%) of the ABC adjusted, if necessary, by the Bidder to current prices using the PSA’s CPI, except under conditions provided for in Section 23.4.2.4 of the 2016 revised IRR of RA No. 9184.

A contract is considered to be “similar” to the contract to be bid if it has the major categories of work stated in the **BDS**.

- 5.3. For Foreign-funded Procurement, the Procuring Entity and the foreign government/foreign or international financing institution may agree on another track record requirement, as specified in the Bidding Document prepared for this purpose.
- 5.4. The Bidders shall comply with the eligibility criteria under Section 23.4.2 of the 2016 IRR of RA No. 9184.

## 6. Origin of Associated Goods

There is no restriction on the origin of Goods other than those prohibited by a decision of the UN Security Council taken under Chapter VII of the Charter of the UN.

## 7. Subcontracts

- 7.1. The Bidder may subcontract portions of the Project to the extent allowed by the Procuring Entity as stated herein, but in no case more than fifty percent (50%) of the Project.

The Procuring Entity has prescribed that: ***Subcontracting is not allowed.***

- 7.2. Subcontracting of any portion of the Project does not relieve the Contractor of any liability or obligation under the Contract. The Supplier will be responsible for the acts, defaults, and negligence of any subcontractor, its agents, servants, or workmen as fully as if these were the Contractor’s own acts, defaults, or negligence, or those of its agents, servants, or workmen.

## 8. Pre-Bid Conference

The Procuring Entity will hold a pre-bid conference for this Project on the specified date and time and either at its physical address at the *Office of the BAC, 2<sup>nd</sup> Floor, Municipal Hall Building, Dagohoy St., Purok 2, Poblacion, Compostela, Davao de Oro* as indicated in paragraph 6 of the **IB**.

## **9. Clarification and Amendment of Bidding Documents**

Prospective bidders may request for clarification on and/or interpretation of any part of the Bidding Documents. Such requests must be in writing and received by the Procuring Entity, either at its given address or through electronic mail indicated in the **IB**, at least ten (10) calendar days before the deadline set for the submission and receipt of Bids.

## **10. Documents Comprising the Bid: Eligibility and Technical Components**

- 10.1. The first envelope shall contain the eligibility and technical documents of the Bid as specified in **Section IX. Checklist of Technical and Financial Documents**.
- 10.2. If the eligibility requirements or statements, the bids, and all other documents for submission to the BAC are in foreign language other than English, it must be accompanied by a translation in English, which shall be authenticated by the appropriate Philippine foreign service establishment, post, or the equivalent office having jurisdiction over the foreign bidder's affairs in the Philippines. For Contracting Parties to the Apostille Convention, only the translated documents shall be authenticated through an apostille pursuant to GPPB Resolution No. 13-2019 dated 23 May 2019. The English translation shall govern, for purposes of interpretation of the bid.
- 10.3. A valid PCAB License is required, and in case of joint ventures, a valid special PCAB License, and registration for the type and cost of the contract for this Project. Any additional type of Contractor license or permit shall be indicated in the **BDS**.
- 10.4. A List of Contractor's key personnel (e.g., Project Manager, Project Engineers, Materials Engineers, and Foremen) assigned to the contract to be bid, with their complete qualification and experience data shall be provided. These key personnel must meet the required minimum years of experience set in the **BDS**.
- 10.5. A List of Contractor's major equipment units, which are owned, leased, and/or under purchase agreements, supported by proof of ownership, certification of availability of equipment from the equipment lessor/vendor for the duration of the project, as the case may be, must meet the minimum requirements for the contract set in the **BDS**.

## **11. Documents Comprising the Bid: Financial Component**

- 11.1. The second bid envelope shall contain the financial documents for the Bid as specified in **Section IX. Checklist of Technical and Financial Documents**.
- 11.2. Any bid exceeding the ABC indicated in paragraph 1 of the **IB** shall not be accepted.
- 11.3. For Foreign-funded procurement, a ceiling may be applied to bid prices provided the conditions are met under Section 31.2 of the 2016 revised IRR of RA No. 9184.

## **12. Alternative Bids**

Bidders shall submit offers that comply with the requirements of the Bidding Documents, including the basic technical design as indicated in the drawings and specifications. Unless there is a value engineering clause in the **BDS**, alternative Bids shall not be accepted.

## **13. Bid Prices**

All bid prices for the given scope of work in the Project as awarded shall be considered as fixed prices, and therefore not subject to price escalation during contract implementation, except under extraordinary circumstances as determined by the NEDA and approved by the GPPB pursuant to the revised Guidelines for Contract Price Escalation guidelines.

## **14. Bid and Payment Currencies**

- 14.1. Bid prices may be quoted in the local currency or tradeable currency accepted by the BSP at the discretion of the Bidder. However, for purposes of bid evaluation, Bids denominated in foreign currencies shall be converted to Philippine currency based on the exchange rate as published in the BSP reference rate bulletin on the day of the bid opening.
- 14.2. Payment of the contract price shall be made in: *Philippine Pesos*.

## **15. Bid Security**

- 15.1. The Bidder shall submit a Bid Securing Declaration or any form of Bid Security in the amount indicated in the **BDS**, which shall be not less than the percentage of the ABC in accordance with the schedule in the **BDS**.
- 15.2. The Bid and bid security shall be valid until *One Hundred Twenty (120) days*. Any bid not accompanied by an acceptable bid security shall be rejected by the Procuring Entity as non-responsive.

## **16. Sealing and Marking of Bids**

Each Bidder shall submit one copy of the first and second components of its Bid.

The Procuring Entity may request additional hard copies and/or electronic copies of the Bid. However, failure of the Bidders to comply with the said request shall not be a ground for disqualification.

If the Procuring Entity allows the submission of bids through online submission to the given website or any other electronic means, the Bidder shall submit an electronic copy of its Bid, which must be digitally signed. An electronic copy that cannot be opened or is corrupted shall be considered non-responsive and, thus, automatically disqualified.

## **17. Deadline for Submission of Bids**

The Bidders shall submit on the specified date and time and either at its physical address or through online submission as indicated in paragraph 7 of the **IB**.

## **18. Opening and Preliminary Examination of Bids**

18.1. The BAC shall open the Bids in public at the time, on the date, and at the place specified in paragraph 9 of the **IB**. The Bidders' representatives who are present shall sign a register evidencing their attendance. In case videoconferencing, webcasting or other similar technologies will be used, attendance of participants shall likewise be recorded by the BAC Secretariat.

In case the Bids cannot be opened as scheduled due to justifiable reasons, the rescheduling requirements under Section 29 of the 2016 revised IRR of RA No. 9184 shall prevail.

18.2. The preliminary examination of Bids shall be governed by Section 30 of the 2016 revised IRR of RA No. 9184.

## **19. Detailed Evaluation and Comparison of Bids**

19.1. The Procuring Entity's BAC shall immediately conduct a detailed evaluation of all Bids rated "*passed*" using non-discretionary pass/fail criteria. The BAC shall consider the conditions in the evaluation of Bids under Section 32.2 of 2016 revised IRR of RA No. 9184.

19.2. If the Project allows partial bids, all Bids and combinations of Bids as indicated in the **BDS** shall be received by the same deadline and opened and evaluated simultaneously so as to determine the Bid or combination of Bids offering the lowest calculated cost to the Procuring Entity. Bid Security as required by **ITB** Clause 15 shall be submitted for each contract (lot) separately.

19.3. In all cases, the NFCC computation pursuant to Section 23.4.2.6 of the 2016 revised IRR of RA No. 9184 must be sufficient for the total of the ABCs for all the lots participated in by the prospective Bidder.

## **20. Post Qualification**

Within a non-extendible period of five (5) calendar days from receipt by the Bidder of the notice from the BAC that it submitted the Lowest Calculated Bid, the Bidder shall submit its latest income and business tax returns filed and paid through the BIR Electronic Filing and Payment System (eFPS), and other appropriate licenses and permits required by law and stated in the **BDS**.

## **21. Signing of the Contract**

The documents required in Section 37.2 of the 2016 revised IRR of RA No. 9184 shall form part of the Contract. Additional Contract documents are indicated in the **BDS**.



## ***Section III. Bid Data Sheet***

# Bid Data Sheet

<b>ITB Clause</b>			
5.2	For this purpose, contracts similar to the Project refer to contracts which have the same major categories of work, which shall be: <b><i>HORIZONTAL CONCRETE WORKS</i></b>		
7.1	<b><i>Subcontracting is not allowed.</i></b>		
10.3	<i>No further instruction.</i>		
10.4	The key personnel must meet the required minimum years of experience set below:		
	<u>Key Personnel</u>	<u>General Experience</u>	<u>Relevant Experience</u>
	Project Engineer	5 years	3 years
	Foreman	3 years	1 year
	Mason	3 years	1 year
	Heavy equipment operator	3 years	1 year
10.5	The minimum major equipment requirements are the following:		
	<u>Equipment</u>	<u>Capacity</u>	<u>Number of Units</u>
	Road Grader		1
	Road Roller		1
	Backhoe		1
	Water Truck		1
	Transit Mixer		1
	Concrete Cutter		1
	Concrete Vibrator		1
	Concrete Screeder		1
	One Bagger Mixer		1
	Welding Machine		1
12	<i>[Insert Value Engineering clause if allowed.]</i>		
15.1	The bid security shall be in the form of a Bid Securing Declaration or any of the following forms and amounts:  a. The amount of not less than P 30,000.00 <i>[Two percent (2%) of ABC]</i> , if bid security is in cash, cashier's/manager's check, bank draft/guarantee or irrevocable letter of credit;  b. The amount of not less than P 75,000.00 <i>[Five percent (5%) of ABC]</i> if bid security is in Surety Bond.		
19.2	Partial bid is not allowed. The infrastructure project is packaged in a single lot and the lot shall not be divided into sub-lots for the purpose of bidding, evaluation, and contract award.		
20	No further instructions.		

21	Additional contract documents are the following: <ul style="list-style-type: none"><li>a. Construction schedule and S-curve</li><li>b. Manpower schedule</li><li>c. Construction methods</li><li>d. Equipment utilization schedule</li><li>e. Construction Safety and Health Program approved by the DOLE</li><li>f. PERT/CPM</li></ul>
----	---

## ***Section IV. General Conditions of Contract***

## 1. Scope of Contract

This Contract shall include all such items, although not specifically mentioned, that can be reasonably inferred as being required for its completion as if such items were expressly mentioned herein. All the provisions of RA No. 9184 and its 2016 revised IRR, including the Generic Procurement Manual, and associated issuances, constitute the primary source for the terms and conditions of the Contract, and thus, applicable in contract implementation. Herein clauses shall serve as the secondary source for the terms and conditions of the Contract.

This is without prejudice to Sections 74.1 and 74.2 of the 2016 revised IRR of RA No. 9184 allowing the GPPB to amend the IRR, which shall be applied to all procurement activities, the advertisement, posting, or invitation of which were issued after the effectivity of the said amendment.

## 2. Sectional Completion of Works

If sectional completion is specified in the **Special Conditions of Contract (SCC)**, references in the Conditions of Contract to the Works, the Completion Date, and the Intended Completion Date shall apply to any Section of the Works (other than references to the Completion Date and Intended Completion Date for the whole of the Works).

## 3. Possession of Site

3.1 The Procuring Entity shall give possession of all or parts of the Site to the Contractor based on the schedule of delivery indicated in the **SCC**, which corresponds to the execution of the Works. If the Contractor suffers delay or incurs cost from failure on the part of the Procuring Entity to give possession in accordance with the terms of this clause, the Procuring Entity's Representative shall give the Contractor a Contract Time Extension and certify such sum as fair to cover the cost incurred, which sum shall be paid by Procuring Entity.

3.2 If possession of a portion is not given by the above date, the Procuring Entity will be deemed to have delayed the start of the relevant activities. The resulting adjustments in contract time to address such delay may be addressed through contract extension provided under Annex "E" of the 2016 revised IRR of RA No. 9184.

## 4. The Contractor's Obligations

The Contractor shall employ the key personnel named in the Schedule of Key Personnel indicating their designation, in accordance with **ITB** Clause 10.3 and specified in the **BDS**, to carry out the supervision of the Works.

The Procuring Entity will approve any proposed replacement of key personnel only if their relevant qualifications and abilities are equal to or better than those of the personnel listed in the Schedule.

## **5. Performance Security**

- 5.1. Within ten (10) calendar days from receipt of the Notice of Award from the Procuring Entity but in no case later than the signing of the contract by both parties, the successful Bidder shall furnish the performance security in any of the forms prescribed in Section 39 of the 2016 revised IRR.
- 5.2. The Contractor, by entering into the Contract with the Procuring Entity, acknowledges the right of the Procuring Entity to institute action pursuant to RA No. 3688 against any subcontractor be they an individual, firm, partnership, corporation, or association supplying the Contractor with labor, materials and/or equipment for the performance of this Contract.

## **6. Site Investigation Reports**

The Contractor, in preparing the Bid, shall rely on any Site Investigation Reports referred to in the SCC supplemented by any information obtained by the Contractor.

## **7. Warranty**

- 7.1. In case the Contractor fails to undertake the repair works under Section 62.2.2 of the 2016 revised IRR, the Procuring Entity shall forfeit its performance security, subject its property(ies) to attachment or garnishment proceedings, and perpetually disqualify it from participating in any public bidding. All payables of the GOP in his favor shall be offset to recover the costs.
- 7.2. The warranty against Structural Defects/Failures, except that occasioned-on force majeure, shall cover the period from the date of issuance of the Certificate of Final Acceptance by the Procuring Entity. Specific duration of the warranty is found in the SCC.

## **8. Liability of the Contractor**

Subject to additional provisions, if any, set forth in the SCC, the Contractor's liability under this Contract shall be as provided by the laws of the Republic of the Philippines.

If the Contractor is a joint venture, all partners to the joint venture shall be jointly and severally liable to the Procuring Entity.

## **9. Termination for Other Causes**

Contract termination shall be initiated in case it is determined *prima facie* by the Procuring Entity that the Contractor has engaged, before, or during the implementation of the contract, in unlawful deeds and behaviors relative to contract acquisition and implementation, such as, but not limited to corrupt, fraudulent, collusive, coercive, and obstructive practices as stated in ITB Clause 4.

## **10. Dayworks**

Subject to the guidelines on Variation Order in Annex “E” of the 2016 revised IRR of RA No. 9184, and if applicable as indicated in the **SCC**, the Dayworks rates in the Contractor’s Bid shall be used for small additional amounts of work only when the Procuring Entity’s Representative has given written instructions in advance for additional work to be paid for in that way.

## **11. Program of Work**

11.1. The Contractor shall submit to the Procuring Entity’s Representative for approval the said Program of Work showing the general methods, arrangements, order, and timing for all the activities in the Works. The submissions of the Program of Work are indicated in the **SCC**.

11.2. The Contractor shall submit to the Procuring Entity’s Representative for approval an updated Program of Work at intervals no longer than the period stated in the **SCC**. If the Contractor does not submit an updated Program of Work within this period, the Procuring Entity’s Representative may withhold the amount stated in the **SCC** from the next payment certificate and continue to withhold this amount until the next payment after the date on which the overdue Program of Work has been submitted.

## **12. Instructions, Inspections and Audits**

The Contractor shall permit the GOP or the Procuring Entity to inspect the Contractor’s accounts and records relating to the performance of the Contractor and to have them audited by auditors of the GOP or the Procuring Entity, as may be required.

## **13. Advance Payment**

The Procuring Entity shall, upon a written request of the Contractor which shall be submitted as a Contract document, make an advance payment to the Contractor in an amount not exceeding fifteen percent (15%) of the total contract price, to be made in lump sum, or at the most two installments according to a schedule specified in the **SCC**, subject to the requirements in Annex “E” of the 2016 revised IRR of RA No. 9184.

## **14. Progress Payments**

The Contractor may submit a request for payment for Work accomplished. Such requests for payment shall be verified and certified by the Procuring Entity’s Representative/Project Engineer. Except as otherwise stipulated in the **SCC**, materials and equipment delivered on the site but not completely put in place shall not be included for payment.

## **15. Operating and Maintenance Manuals**

15.1. If required, the Contractor will provide “as built” Drawings and/or operating and maintenance manuals as specified in the **SCC**.

- 15.2. If the Contractor does not provide the Drawings and/or manuals by the dates stated above, or they do not receive the Procuring Entity's Representative's approval, the Procuring Entity's Representative may withhold the amount stated in the **SCC** from payments due to the Contractor.



## ***Section V. Special Conditions of Contract***

# Special Conditions of Contract

GCC Clause	
2	<i>Not applicable.</i>
4.1	<i>The procuring entity shall give possession of all parts of the site to the contractor upon receipt of the NTP.</i>
6	The site investigation reports are: <i>none</i>
7.2	Five (5) years.
10	No dayworks are applicable to the contract.
11.1	The Contractor shall submit the Program of Work to the Procuring Entity's Representative within <i>Ten (10)</i> days of delivery of the Notice of Award.
11.2	The amount to be withheld for late submission of an updated Program of Work is Fifty Thousand Pesos (P50,000.00).
13	The amount of the advance payment shall not exceed 15% of the total contract price which will only be released upon complete mobilization.
14	Materials and equipment delivered on the site but not completely put in place shall be included for payment.
15.1	The date by which operating and maintenance manuals are required is upon acceptance of the project.  The date by which "as built" drawings are required is prior to the release of certificate of completion.
15.2	The amount to be withheld for failing to produce "as built" drawings and/or operating and maintenance manuals by the date required is <i>one percent (1%) of the contract amount.</i>

## *Section VI. Specifications*

**PROJECT NAME: CONCRETING OF BLOCK ROADS @ P-1 PUBLIC MARKET**

***DESCRIPTION: CONCRETING OF 87.30 L.M. PCCP WITH 83 L.M. CONCRETE DRAINAGE:***

- 87.30 M X 4.40M X 0.20M THK. PCCP
- 83 L.M CONCRETE DRAINAGE WITH STEEL GRATING COVER
- CONCRETE SLAB ON FILL AND CONCRETE GUTTER

***LOCATION: P-1, Poblacion ,Compostela, Davao de Oro***

**GENERAL CONDITION & SPECIFICATIONS**

**GENERAL CONDITION**

**1. GENERAL**

The drawing and the specifications are complementary to each other. Drawings are graphic means of showing work to be done. They are particularly suited to showing where materials are located. Thus, drawing exists essentially to show dimensions, location and placement. Not all works however can be presented in the drawings. Any doubts in the part of contractor shall be refer to the Municipal Engineer or the project engineer on site. Generalized works are usually in statement form, and hence the contractor is required to read the specifications carefully.

Specifications, on the other hand, are used to describe the materials, construction techniques, samples, shop drawings, guarantees and other contract requirements. Together, the drawing and the specifications are used to inform the contractor. In cases where the specified brand carries with it the manufacturer's specifications, the manufacturer's specifications shall hold precedence over these specifications.

**2. SPECIFICATION**

*ITEM 100 – CLEARING AND GRUBBING*

**100.1 Description**

This item shall consist of clearing, grubbing, removing and disposing all vegetation and debris as designated in the Contract, except those objects that are designated to remain in place or are to be removed in consonance with other provisions of this Specification. The work shall also include the preservation from injury or defacement of all objects designated to remain.

**100.2 Construction Requirements**

**100.2.1 General**

The Engineer will establish the limits of work and designate all trees, shrubs, plants and other things to remain. The Contractor shall preserve all objects designated to remain. Paint required for cut or scarred surface of trees or shrubs selected for retention shall be an approved asphaltum base paint prepared especially for tree surgery.

Clearing shall extend one (1) meter beyond the toe of the fill slopes or beyond rounding of cut slopes as the case maybe for the entire length of the project unless otherwise shown on the plans or as directed by the Engineer and provided it is within the right of way limits of the project, with the exception of trees under the jurisdiction of the Forest Management Bureau (FMB).

### **100.2.2 Clearing and Grubbing**

All surface objects and all trees, stumps, roots and other protruding obstructions, not designated to remain, shall be cleared and/or grubbed, including mowing as required, except as provided below:

- (1) Removal of undisturbed stumps and roots and nonperishable solid objects with a minimum depth of one (1) meter below subgrade or slope of embankment will not be required.
- (2) In areas outside of the grading limits of cut and embankment areas, stumps and nonperishable solid objects shall be cut off not more than 150 mm (6 inches) above the ground line or low water level.
- (3) In areas to be rounded at the top of cut slopes, stumps shall be cut off flush with or below the surface of the final slope line.
- (4) Grubbing of pits, channel changes and ditches will be required only to the depth necessitated by the proposed excavation within such areas.
- (5) In areas covered by cogon/talahib, wild grass and other vegetations, top soil shall be cut to a maximum depth of 150 mm below the original ground surface or as designated by the Engineer, and disposed outside the clearing and grubbing limits as indicated in the typical roadway section.

Except in areas to be excavated, stump holes and other holes from which obstructions are removed shall be backfilled with suitable material and compacted to the required density.

If perishable material is burned, it shall be burned under the constant care of component watchmen at such times and in such a manner that the surrounding vegetation, other adjacent property, or anything designated to remain on the right of way will not be jeopardized. If permitted, burning shall be done in accordance with applicable laws, ordinances, and regulation.

The Contractor shall use high intensity burning procedures, (i.e., incinerators, high stacking or pit and ditch burning with forced air supplements) that produce intense burning with little or no visible smoke emission during the burning process. At the conclusion of each burning session, the fire shall be completely extinguished so that no smoldering debris remains.

In the event that the Contractor is directed by the Engineer not to start burning operations or to suspend such operations because of hazardous weather conditions, material to be burned which interferes with subsequent construction operations shall be moved by the Contractor to

temporary locations clear of construction operations and later, if directed by the Engineer, shall be placed on a designated spot and burned.

Materials and debris which cannot be burned and perishable materials may be disposed off by methods and at locations approved by the Engineer, on or off the project. If disposal is by burying, the debris shall be placed in layers with the material so disturbed to avoid nesting. Each layer shall be covered or mixed with earth material by the land-fill method to fill all voids. The top layer of material buried shall be covered with at least 300 mm (12 inches) of earth or other approved material and shall be graded, shaped and compacted to present a pleasing appearance. If the disposal location is off the project, the Contractor shall make all necessary arrangements with property owners in writing for obtaining suitable disposal locations which are outside the limits of view from the project. The cost involved shall be included in the unit bid price. A copy of such agreement shall be furnished to the Engineer. The disposal areas shall be seeded, fertilized and mulched at the Contractor's expense.

Woody material may be disposed off by chipping. The wood chips may be used for mulch, slope erosion control or may be uniformly spread over selected areas as directed by the Engineer. Wood chips used as mulch for slope erosion control shall have a maximum thickness of 12 mm (1/2 inch) and faces not exceeding 3900 mm<sup>2</sup> (6 square inches) on any individual surface area. Wood chips not designated for use under other sections shall be spread over the designated areas in layers not to exceed 75 mm (3 inches) loose thickness. Diseased trees shall be buried or disposed off as directed by the Engineer.

All merchantable timber in the clearing area which has not been removed from the right of way prior to the beginning of construction, shall become the property of the Contractor, unless otherwise provided.

Low hanging branches and unsound or unsightly branches on trees or shrubs designated to remain shall be trimmed as directed. Branches of trees extending over the roadbed shall be trimmed to give a clear height of 6 m (20 feet) above the roadbed surface. All trimming shall be done by skilled workmen and in accordance with good tree surgery practices.

Timber cut inside the area staked for clearing shall be felled within the area to be cleared.

### **100.2.3 Individual Removal of Trees or Stumps**

Individual trees or stumps designated by the Engineer for removal and located in areas other than those established for clearing and grubbing and roadside cleanup shall be removed and disposed off as specified under Subsection 100.2.2 except trees removed shall be cut as nearly flush with the ground as practicable without removing stumps.

### **100.3 Method of Measurement**

Measurement will be by one or more of the following alternate methods:

1. Area Basis. The work to be paid for shall be the number of hectares and fractions thereof acceptably cleared and grubbed within the limits indicated on the Plans or as may be adjusted in field staking by the Engineer. Areas not within the clearing and grubbing limits shown on the Plans or not staked for clearing and grubbing will not be measured for payment.

2. Lump-Sum Basis. When the Bill of Quantities contains a Clearing and Grubbing lump-sum item, no measurement of area will be made for such item.
3. Individual Unit Basis (Selective Clearing). The diameter of trees will be measured at a height of 1.4 m (54 inches) above the ground. Trees less than 150 mm (6 inches) in diameter will not be measured for payment.

When Bill of Quantities indicates measurement of trees by individual unit basis, the units will be designated and measured in accordance with the following schedule of sizes:

Diameter at height of 1.4 m	Pay Item Designation
Over 150 mm to 900 mm	Small
Over 900 mm	Large

#### 100.4 Basis of Payment

The accepted quantities, measured as prescribed in Section 100.3, shall be paid for at the Contract unit price for each of the Pay Items listed below that is included in the Bill of Quantities, which price and payment shall be full compensation for furnishing all labor, equipment, tools and incidentals necessary to complete the work prescribed in this Item.

Payment will be made under:

Pay Item Number	Description	Unit of Measurement
100 (1)	Clearing and Grubbing	Hectare
100 (2)	Clearing and Grubbing	Lump Sum
100 (3)	Individual Removal of Trees, Small	Each
100 (4)	Individual removal of Trees, Large	Each

### ITEM 102 – EXCAVATION

#### 102.1 Description

This Item shall consist of roadway and drainage and borrow excavation and the disposal of material in accordance with this Specification and in conformity with the lines, grades and dimensions shown on the Plans or established by the Engineer.

##### 102.1.1 Roadway Excavation

Roadway excavation will include excavation and grading for roadways, parking areas, intersections, approaches, slope rounding, benching, waterways and ditches; removal of

unsuitable material from the roadbed and beneath embankment areas; and excavating selected material found in the roadway as ordered by the Engineer for specific use in the improvement. Roadway excavation will be classified as “unclassified excavation”, “rock excavation”, “common excavation”, or “muck excavation” as indicated in the Bill of Quantities and hereinafter described.

(1) **Unclassified Excavation.** Unclassified excavation shall consist of the excavation and disposal of all materials regardless of its nature, not classified and included in the Bill of Quantities under other pay items.

(2) **Rock Excavation.** Rock excavation shall consist of igneous, sedimentary and metamorphic rock which cannot be excavated without blasting or the use of rippers, and all boulders or other detached stones each having a volume of 1 cubic meter or more as determined by physical measurements or visually by the Engineer.

(3) **Common Excavation.** Common excavations shall consist of all excavation not included in the Bill of Quantities under “rock excavation” or other pay items.

(4) **Muck Excavation.** Muck excavation shall consist of the removal and disposal of deposits of saturated or unsaturated mixtures of soils and organic matter not suitable for foundation material regardless of moisture content.

#### **102.1.2 Borrow Excavation**

Borrow excavation shall consist of the excavation and utilization of approved material required for the construction of embankments or for other portions of the work, and shall be obtained from approved sources, in accordance with Clause 61 and the following:

(1) **Borrow, Case 1**

Borrow Case 1 will consist of material obtained from sources designated on the Plans or in the Special Provisions.

(2) **Borrow, Case 2**

Borrow Case 2 will consist of material obtained from sources provided by the Contractor.

The material shall meet the quality requirements determined by the Engineer unless otherwise provided in the Contract.

### **102.2 Construction Requirements**

#### **102.2.1 General**

When there is evidence of discrepancies on the actual elevations and that shown on the Plans, a pre-construction survey referred to the datum plane used in the approved Plan shall be undertaken by the Contractor under the control of the Engineer to serve as basis for the computation of the actual volume of the excavated materials.

All excavations shall be finished to reasonably smooth and uniform surfaces. No materials shall be wasted without authority of the Engineer. Excavation operations shall be conducted so that material outside of the limits of slopes will not be disturbed. Prior to excavation, all



necessary clearing and grubbing in that area shall have been performed in accordance with Item 100, Clearing and Grubbing.

### **102.2.2 Conservation of Topsoil**

Where provided for on the Plans or in the Special Provisions, suitable topsoil encountered in excavation and on areas where embankment is to be placed shall be removed to such extent and to such depth as the Engineer may direct. The removed topsoil shall be transported and deposited in storage piles at locations approved by the Engineer. The topsoil shall be completely removed to the required depth from any designated area prior to the beginning of regular excavation or embankment work in the area and shall be kept separate from other excavated materials for later use.

### **102.2.3 Utilization of Excavated Materials**

All suitable material removed from the excavation shall be used in the formation of the embankment, subgrade, shoulders, slopes, bedding, and backfill for structures, and for other purposes shown on the Plans or as directed.

The Engineer will designate as unsuitable those soils that cannot be properly compacted in embankments. All unsuitable material shall be disposed off as shown on the Plans or as directed without delay to the Contractor.

Only approved materials shall be used in the construction of embankments and backfills.

All excess material, including rock and boulders that cannot be used in embankments shall be disposed off as directed.

Material encountered in the excavation and determined by the Engineer as suitable for topping, road finishing, slope protection, or other purposes shall be conserved and utilized as directed by the Engineer.

Borrow material shall not be placed until after the readily accessible roadway excavation has been placed in the fill, unless otherwise permitted or directed by the Engineer. If the Contractor places more borrow than is required and thereby causes a waste of excavation, the amount of such waste will be deducted from the borrow volume.

### **102.2.4 Prewatering**

Excavation areas and borrow pits may be prewatered before excavating the material. When prewatering is used, the areas to be excavated shall be moistened to the full depth, from the surface to the bottom of the excavation. The water shall be controlled so that the excavated material will contain the proper moisture to permit compaction to the specified density with the use of standard compacting equipment. Prewatering shall be supplemented where necessary, by truck watering units, to ensure that the embankment material contains the proper moisture at the time of compaction.

The Contractor shall provide drilling equipment capable of suitably checking the moisture penetration to the full depth of the excavation.

### **102.2.5 Presplitting**

Unless otherwise provided in the Contract, rock excavation which requires drilling and shooting shall be presplit.

Presplitting to obtain faces in the rock and shale formations shall be performed by: (1) drilling holes at uniform intervals along the slope lines, (2) loading and stemming the holes with appropriate explosives and stemming material, and (3) detonating the holes simultaneously.

Prior to starting drilling operations for presplitting, the Contractor shall furnish the Engineer a plan outlining the position of all drill holes, depth of drilling, type of explosives to be used, loading pattern and sequence of firing. The drilling and blasting plan is for record purposes only and will not absolve the Contractor of his responsibility for using proper drilling and blasting procedures. Controlled blasting shall begin with a short test section of a length approved by the Engineer. The test section shall be presplit, production drilled and blasted and sufficient material excavated whereby the Engineer can determine if the Contractor's methods are satisfactory. The Engineer may order discontinuance of the presplitting when he determines that the materials encountered have become unsuitable for being presplit.

The holes shall be charged with explosives of the size, kind, strength, and at the spacing suitable for the formations being presplit, and with stemming material which passes a 9.5 mm (3/8 inch) standard sieve and which has the qualities for proper confinement of the explosives.

The finished presplit slope shall be reasonably uniform and free of loose rock. Variance from the true plane of the excavated backslope shall not exceed 300 mm (12 inches); however, localized irregularities or surface variations that do not constitute a safety hazard or an impairment to drainage courses or facilities will be permitted.

A maximum offset of 600 mm (24 inches) will be permitted for a construction working bench at the bottom of each lift for use in drilling the next lower presplitting pattern.

### **102.2.6 Excavation of Ditches, Gutters, etc.**

All materials excavated from **side ditches** and gutters, channel changes, irrigation ditches, inlet and outlet ditches, toe ditchers, furrow ditches, and such other ditches as may be designated on the Plans or staked by the Engineer, shall be utilized as provided in Subsection 102.2.3.

**Ditches** shall conform to the slope, grade, and shape of the required cross-section, with no projections of roots, stumps, rock, or similar matter. The Contractor shall maintain and keep open and free from leaves, sticks, and other debris all ditches dug by him until final acceptance of the work.

Furrow ditches shall be formed by plowing a continuous furrow along the line staked by the Engineer. Methods other than plowing may be used if acceptable to the Engineer. The ditches shall be cleaned out by hand shovel work, by ditcher, or by some other suitable method, throwing all loose materials on the downhill side so that the bottom of the finished ditch shall be approximately 450 mm (18 inches) below the crest of the loose material piled on the

downhill side. Hand finish will not be required, but the flow lines shall be in satisfactory shape to provide drainage without overflow.

#### **102.2.7 Excavation of Roadbed Level**

Rock shall be excavated to a depth of 150 mm (6 inches) below subgrade within the limits of the roadbed, and the excavation backfilled with material designated on the Plans or approved by the Engineer and compacted to the required density.

When excavation methods employed by the Contractor leave undrained pockets in the rock surface, the Contractor shall at his own expense, properly drain such depressions or when permitted by the Engineer fill the depressions with approved impermeable material.

Material below subgrade, other than solid rock shall be thoroughly scarified to a depth of 150 mm (6 inches) and the moisture content increased or reduced, as necessary, to bring the material throughout this 150 mm layer to the moisture content suitable for maximum compaction. This layer shall then be compacted in accordance with Subsection 104.3.3.

#### **102.2.8 Borrow Areas**

The Contractor shall notify the Engineer sufficiently in advance of opening any borrow areas so that cross-section elevations and measurements of the ground surface after stripping may be taken, and the borrow material can be tested before being used. Sufficient time for testing the borrow material shall be allowed.

All borrow areas shall be bladed and left in such shape as to permit accurate measurements after excavation has been completed. The Contractor shall not excavate beyond the dimensions and elevations established, and no material shall be removed prior to the staking out and cross-sectioning of the site. The finished borrow areas shall be approximately true to line and grade established and specified and shall be finished, as prescribed in Clause 61, Standard Specifications for Public Works and Highways, Volume 1. When necessary to remove fencing, the fencing shall be replaced in at least as good condition as it was originally. The Contractor shall be responsible for the confinement of livestock when a portion of the fence is removed.

#### **102.2.9 Removal of Unsuitable Material**

Where the Plans show the top portion of the roadbed to be selected topping, all unsuitable materials shall be excavated to the depth necessary for replacement of the selected topping to the required compacted thickness.

Where excavation to the finished graded section results in a subgrade or slopes of unsuitable soil, the Engineer may require the Contractor to remove the unsuitable material and backfill to the finished graded section with approved material. The Contractor shall conduct his operations in such a way that the Engineer can take the necessary cross-sectional measurements before the backfill is placed.

The excavation of muck shall be handled in a manner that will not permit the entrapment of muck within the backfill. The material used for backfilling up to the ground line or water

level, whichever is higher, shall be rock or other suitable granular material selected from the roadway excavation, if available. If not available, suitable material shall be obtained from other approved sources. Unsuitable material removed shall be disposed off in designated areas shown on the Plans or approved by the Engineer.

### 102.3 Method of Measurement

The cost of excavation of material which is incorporated in the Works or in other areas of fill shall be deemed to be included in the Items of Work where the material is used.

Measurement of Unsuitable or Surplus Material shall be the net volume in its original position.

For measurement purposes, surplus suitable material shall be calculated as the difference between the net volume of suitable material required to be used in embankment corrected by applying a shrinkage factor or a swell factor in case of rock excavation, determined by laboratory tests to get its original volume measurement, and the net volume of suitable material from excavation in the original position. Separate pay items shall be provided for surplus common, unclassified and rock material.

The Contractor shall be deemed to have included in the contract unit prices all costs of obtaining land for the disposal of unsuitable or surplus material.

### 102.4 Basis of Payment

The accepted quantities, measured as prescribed in Section 102.3 shall be paid for at the contract unit price for each of the Pay Items listed below that is included in the Bill of Quantities which price and payment shall be full compensation for the removal and disposal of excavated materials including all labor, equipment, tools, and incidentals necessary to complete the work prescribed in this Item.

Payment will be made under:

Pay Item Number	Description	Unit of Measurement
102 (1)	Unsuitable Excavation	Cubic Meter
102 (2)	Surplus Common Excavation	Cubic Meter
102 (3)	Surplus Rock Excavation	<i>Cubic Meter</i>
102 (4)	Surplus Unclassified Excavation	Cubic Meter

## ITEM 103 – STRUCTURE EXCAVATION

### 103.1 Description

This Item shall consist of the necessary excavation for foundation of bridges, culverts, underdrains, and other structures not otherwise provided for in the Specifications. Except as otherwise provided for pipe culverts, the backfilling of completed structures and the disposal of all excavated surplus materials, shall be in accordance with these Specifications and in reasonably close conformity with the Plans or as established by the Engineer.

This Item shall include necessary diverting of live streams, bailing, pumping, **draining**, sheeting, bracing, and the necessary construction of cribs and cofferdams, and furnishing the materials therefore, and the subsequent removal of cribs and cofferdams and the placing of all necessary backfill.

It shall also include the furnishing and placing of approved foundation fill material to replace unsuitable material encountered below the foundation elevation of structures.

No allowance will be made for classification of different types of material encountered.

## **103.2 Construction Requirements**

### **103.2.1 Clearing and Grubbing**

Prior to starting excavation operations in any area, all necessary clearing and grubbing in that area shall have been performed in accordance with Item 100, Clearing and Grubbing.

### **103.2.2 Excavation**

(1) General, all structures. The Contractor shall notify the Engineer sufficiently in advance of the beginning of any excavation so that cross-sectional elevations and measurements may be taken on the undisturbed ground. The natural ground adjacent to the structure shall not be disturbed without permission of the Engineer.

Trenches or foundation pits for structures or structure footings shall be excavated to the lines and grades or elevations shown on the Plans or as staked by the Engineer. They shall be of sufficient size to permit the placing of structures or structure footings of the full width and length shown. The elevations of the bottoms of footings, as shown on the Plans, shall be considered as approximate only and the Engineer may order, in writing, such changes in dimensions or elevations of footings as may be deemed necessary, to secure a satisfactory foundation.

Trenches or foundation pits for structures or structure footings shall be excavated to the lines and grades or elevations shown on the Plans or as staked by the Engineer. They shall be of sufficient size to permit the placing of structures or structure footings of the full width and length shown. The elevations of the bottoms of footings, as shown on the Plans, shall be considered as approximate only and the Engineer may order, in writing, such changes in dimensions or elevations of footings as may be deemed necessary, to secure a satisfactory foundation.

(2) Structures other than pipe culverts. All rock or other hard foundation materials shall be cleaned all loose materials, and cut to a firm surface, either level, stepped, or serrated as directed by the Engineer. All seams or crevices shall be cleaned and grouted. All loose and disintegrated rocks and thin strata shall be removed. When the footing is to rest on material other than rock, excavation to final grade shall not be made until just before the footing is to be placed. When the foundation material is soft or mucky or otherwise unsuitable, as determined by the Engineer, the Contractor shall remove the unsuitable material and backfill with approved granular material. This foundation fill shall be placed and compacted in 150 mm (6 inches) layers up to the foundation elevation.

When foundation piles are used, the excavation of each pit shall be completed before the piles are driven and any placing of foundation fill shall be done after the piles are driven. After the driving is completed, all loose and displaced materials shall be removed, leaving a smooth, solid bed to receive the footing.

(3) Pipe Culverts. The width of the pipe trench shall be sufficient to permit satisfactory jointing of the pipe and thorough tamping of the bedding material under and around the pipe.

Where rock, hardpan, or other unyielding material is encountered, it shall be removed below the foundation grade for a depth of at least 300 mm or 4 mm for each 100 mm of fill over the top of pipe, whichever is greater, but not to exceed three-quarters of the vertical inside diameter of the pipe. The width of the excavation shall be at least 300 mm (12 inches) greater than the horizontal outside diameter of the pipe. The excavation below grade shall be backfilled with selected fine compressible material, such as silty clay or loam, and lightly compacted in layers not over 150 mm (6 inches) in uncompacted depth to form a uniform but yielding foundation.

Where a firm foundation is not encountered at the grade established, due to soft, spongy, or other unstable soil, such unstable soil under the pipe and for a width of at least one diameter on each side of the pipe shall be removed to the depth directed by the Engineer and replaced with approved granular foundation fill material properly compacted to provide adequate support for the pipe, unless other special construction methods are called for on the Plans.

The foundation surface shall provide a firm foundation of uniform density throughout the length of the culvert and, if directed by the Engineer, shall be cambered in the direction parallel to the pipe centerline.

Where pipe culverts are to be placed in trenches excavated in embankments, the excavation of each trench shall be performed after the embankment has been constructed to a plane parallel to the proposed profile grade and to such height above the bottom of the pipe as shown on the Plans or directed by the Engineer.

### **103.2.3 Utilization of Excavated Materials**

All excavated materials, so far as suitable, shall be utilized as backfill or embankment. The surplus materials shall be disposed off in such manner as not to obstruct the stream or otherwise impair the efficiency or appearance of the structure. No excavated materials shall be deposited at any time so as to endanger the partly finished structure.

### **103.2.4 Cofferdams**

Suitable and practically watertight cofferdams shall be used wherever water-bearing strata are encountered above the elevation of the bottom of the excavation. If requested, the Contractor shall submit drawings showing his proposed method of cofferdam construction, as directed by the Engineer.

Cofferdams or cribs for foundation construction shall in general, be carried well below the bottoms of the footings and shall be well braced and as nearly watertight as practicable. In general, the interior dimensions of cofferdams shall be such as to give sufficient clearance for the construction of forms and the inspection of their exteriors, and to permit pumping outside

of the forms. Cofferdams or cribs which are tilted or moved laterally during the process of sinking shall be righted or enlarged so as to provide the necessary clearance.

When conditions are encountered which, as determined by the Engineer, render it impracticable to dewater the foundation before placing the footing, the Engineer may require the construction of a concrete foundation seal of such dimensions as he may consider necessary, and of such thickness as to resist any possible uplift. The concrete for such seal shall be placed as shown on the Plans or directed by the Engineer. The foundation shall then be dewatered and the footing placed. When weighted cribs are employed and the mass is utilized to overcome partially the hydrostatic pressure acting against the bottom of the foundation seal, special anchorage such as dowels or keys shall be provided to transfer the entire mass of the crib to the foundation seal. When a foundation seal is placed under water, the cofferdams shall be vented or ported at low water level as directed.

Cofferdams shall be constructed so as to protect green concrete against damage from sudden rising of the stream and to prevent damage to the foundation by erosion. No timber or bracing shall be left in cofferdams or cribs in such a way as to extend into substructure masonry, without written permission from the Engineer.

Any pumping that may be permitted from the interior of any foundation enclosure shall be done in such a manner as to preclude the possibility of any portion of the concrete material being carried away. Any pumping required during the placing of concrete, or for a period of at least 24 hours thereafter, shall be done from a suitable sump located outside the concrete forms. Pumping to dewater a sealed cofferdam shall not commence until the seal has set sufficiently to withstand the hydrostatic pressure.

Unless otherwise provided, cofferdams or cribs, with all sheeting and bracing involved therewith, shall be removed by the Contractor after the completion of the substructure. Removal shall be effected in such manner as not to disturb or mar finished masonry.

### **103.2.5 Preservation of Channel**

Unless otherwise permitted, no excavation shall be made outside of caissons, cribs, cofferdams, or sheet piling, and the natural stream bed adjacent to structure shall not be disturbed without permission from the Engineer. If any excavation or dredging is made at the side of the structure before caissons, cribs, or cofferdams are sunk in place, the Contractor shall, after the foundation base is in place, backfill all such excavations to the original ground surface or stream bed with material satisfactory to the Engineer.

### **103.2.6 Backfill and Embankment for Structures Other Than Pipe Culverts**

Excavated areas around structures shall be backfilled with free draining granular material approved by the Engineer and placed in horizontal layers not over 150 mm (6 inches) in thickness, to the level of the original ground surface. Each layer shall be moistened or dried as required and thoroughly compacted with mechanical tampers.

In placing backfills or embankment, the material shall be placed simultaneously in so far as possible to approximately the same elevation on both sides of an abutment, pier, or wall. If conditions require placing backfill or embankment appreciably higher on one side than on the

opposite side, the additional material on the higher side shall not be placed until the masonry has been in place for 14 days, or until tests made by the laboratory under the supervision of the Engineer establishes that the masonry has attained sufficient strength to withstand any pressure created by the methods used and materials placed without damage or strain beyond a safe factor.

Backfill or embankment shall not be placed behind the walls of concrete culverts or abutments or rigid frame structures until the top slab is placed and cured. Backfill and embankment behind abutments held at the top by the superstructure, and behind the sidewalls of culverts, shall be carried up simultaneously behind opposite abutments or sidewalls.

All embankments adjacent to structures shall be constructed in horizontal layers and compacted as prescribed in Subsection 104.3.3 except that mechanical tampers may be used for the required compaction. Special care shall be taken to prevent any wedging action against the structure and slopes bounding or within the areas to be filled shall be benched or serrated to prevent wedge action. The placing of embankment and the benching of slopes shall continue in such a manner that at all times there will be horizontal berm of thoroughly compacted material for a distance at least equal to the height of the abutment or wall to the backfilled against except insofar as undisturbed material obtrudes upon the area.

Broken rock or coarse sand and gravel shall be provided for a drainage filter at weepholes as shown on the Plans.

### **103.2.7 Bedding, Backfill, and Embankment for Pipe Culverts**

Bedding, Backfill and Embankment for pipe culverts shall be done in accordance with Item 500, Pipe Culverts and Storm Drains.

## **103.3 Method of Measurement**

### **103.3.1 Structure Excavation**

The volume of excavation to be paid for will be the number of cubic metres measured in original position of material acceptably excavated in conformity with the Plans or as directed by the Engineer, but in no case, except as noted, will any of the following volumes be included in the measurement for payment:

- (1) The volume outside of vertical planes 450 mm (18 inches) outside of and parallel to the neat lines of footings and the inside walls of pipe and pipe-arch culverts at their widest horizontal dimensions.
- (2) The volume of excavation for culvert and sections outside the vertical plane for culverts stipulated in (1) above.
- (3) The volume outside of neat lines of underdrains as shown on the Plans, and outside the limits of foundation fill as ordered by the Engineer.
- (4) The volume included within the staked limits of the roadway excavation, contiguous channel changes, ditches, etc., for which payment is otherwise provided in the Specification.



(5) Volume of water or other liquid resulting from construction operations and which can be pumped or drained away.

(6) The volume of any excavation performed prior to the taking of elevations and measurements of the undisturbed ground.

(7) the volume of any material rehandled, except that where the Plans indicate or the Engineer directs the excavation after embankment has been placed and except that when installation of pipe culverts by the imperfect trench method specified in Item 500 is required, the volume of material re-excavated as directed will be included.

(8) The volume of excavation for footings ordered at a depth more than 1.5 m (60 inches) below the lowest elevation for such footings shown on the original Contract Plans, unless the Bill of Quantities contains a pay item for excavation ordered below the elevations shown on the Plans for individual footings.

### **103.3.2 Bridge Excavation**

The volume of excavation, designated on the Plans or in the Special Provisions as “Bridge Excavation” will be measured as described below and will be kept separate for pay purposes from the excavation for all structures.

The volume of bridge excavation to be paid shall be the vertical 450 mm (18 inches) outside of and parallel to the neat lines of the footing. The vertical planes shall constitute the vertical faces of the volume for pay quantities regardless of excavation inside or outside of these planes.

### **103.3.3 Foundation Fill**

The volume of foundation fill to be paid for will be the number of cubic metres measures in final position of the special granular material actually provided and placed below the foundation elevation of structures as specified, complete in place and accepted.

### **103.3.4 Shoring, Cribbing, and Related Work**

Shoring, cribbing and related work whenever included as a pay item in Bill of Quantities will be paid for at the lump sum bid price. This work shall include furnishing, constructing, maintaining, and removing any and all shoring, cribbing, cofferdams, caissons, bracing, sheeting water control, and other operations necessary for the acceptable completion of excavation included in the work of this Section, to a depth of 1.5 m below the lowest elevation shown on the Plans for each separable foundation structure.

### **103.3.5 Basis of Payment**

The accepted quantities, measured as prescribed in Section 103.3, shall be paid for at the contract unit price for each of the particular pay items listed below that is included in the Bill of Quantities. The payment shall constitute full compensation for the removal and disposal of excavated materials including all labor, equipment, tools and incidentals necessary to complete the work prescribed in this Item, except as follows:

(1) Any excavation for footings ordered at a depth more than 1.5 m below the lowest elevation shown on the original Contract Plans will be paid for as provided in Part K, Measurement and Payment, unless a pay item for excavation ordered below Plan elevation appears in the Bill of Quantities.

(2) Concrete will be measured and paid for as provided under Item 405, Structural Concrete.

(3) Any roadway or borrow excavation required in excess of the quantity excavated for structures will be measured and paid for as provided under Item 102.

(4) Shoring, cribbing, and related work required for excavation ordered more than 1.5 m (60 inches ) below Plan elevation will be paid for in accordance with Part K.

Payment will be made under:

Pay Item Number	Description	Unit of Measurement
103 (1)	Structure Excavation	Cubic Meter
103 (2)	Bridge Excavation	Cubic Meter
103 (3)	Foundation Fill	Cubic Meter
103 (4)	Excavation ordered below Plan elevation	Cubic Meter
103 (5)	Shoring, cribbing, and related work	Lump sum
103 (6)	Pipe culverts and drain excavation	Cubic Meter

## ITEM 104 – EMBANKMENT

### 104.1 Description

This Item shall consist of the construction of embankment in accordance with this Specification and in conformity with the lines, grades and dimensions shown on the Plans or established by the Engineer.

### 104.2 Material Requirements

Embankments shall be constructed of suitable materials, in consonance with the following definitions:

1. Suitable Material – Material which is acceptable in accordance with the Contract and which can be compacted in the manner specified in this Item. It can be common material or rock.

Selected Borrow, for topping – soil of such gradation that all particles will pass a sieve with 75 mm (3 inches) square openings and not more than 15 mass percent will pass the 0.075 mm (No. 200) sieve, as determined by AASHTO T 11. The material shall have a plasticity index

of not more than 6 as determined by ASSHTO T 90 and a liquid limit of not more than 30 as determined by AASHTO T 89.

2. Unsuitable Material – Material other than suitable materials such as:
  - (a) Materials containing detrimental quantities of organic materials, such as grass, roots and sewerage.
  - (b) Organic soils such as peat and muck.
  - (c) Soils with liquid limit exceeding 80 and/or plasticity index exceeding 55.
  - (d) Soils with a natural water content exceeding 100%.
  - (e) Soils with very low natural density,  $800 \text{ kg/m}^3$  or lower.
  - (f) Soils that cannot be properly compacted as determined by the Engineer.

### **104.3 Construction Requirements**

#### **104.3.1 General**

Prior to construction of embankment, all necessary clearing and grubbing in that area shall have been performed in conformity with Item 100, Clearing and Grubbing.

Embankment construction shall consist of constructing roadway embankments, including preparation of the areas upon which they are to be placed; the construction of dikes within or adjacent to the roadway; the placing and compacting of approved material within roadway areas where unsuitable material has been removed; and the placing and compacting of embankment material in holes, pits, and other depressions within the roadway area.

Embankments and backfills shall contain no muck, peat, sod, roots or other deleterious matter. Rocks, broken concrete or other solid, bulky materials shall not be placed in embankment areas where piling is to be placed or driven.

Where shown on the Plans or directed by the Engineer, the surface of the existing ground shall be compacted to a depth of 150 mm (6 inches) and to the specified requirements of this Item.

Where provided on the Plans and Bill of Quantities the top portions of the roadbed in both cuts and embankments, as indicated, shall consist of selected borrow for topping from excavations.

#### **104.3.2 Methods of Construction**

Where there is evidence of discrepancies on the actual elevations and that shown on the Plans, a preconstruction survey referred to the datum plane used in the approved Plan shall be undertaken by the Contractor under the control of the Engineer to serve as basis for the computation of the actual volume of the embankment materials.

When embankment is to be placed and compacted on hillsides, or when new embankment is to be compacted against existing embankments, or when embankment is built one-half width at a time, the existing slopes that are steeper than 3:1 when measured at right angles to the roadway shall be continuously benched over those areas as the work is brought up in layers. Benching will be subject to the Engineer's approval and shall be of sufficient width to permit operation of placement and compaction equipment. Each horizontal cut shall begin at the intersection of the original ground and the vertical sides of the previous cuts. Material thus excavated shall be placed and compacted along with the embankment material in accordance with the procedure described in this Section.

Unless shown otherwise on the Plans or special Provisions, where an embankment of less than 1.2 m (4 feet) below subgrade is to be made, all sod and vegetable matter shall be removed from the surface upon which the embankment is to be placed, and the cleared surface shall be completely broken up by plowing, scarifying, or steeping to a minimum depth of 150 mm except as provided in Subsection 102.2.2. This area shall then be compacted as provided in Subsection 104.3.3. Sod not required to be removed shall be thoroughly disc harrowed or scarified before construction of embankment. Wherever a compacted road surface containing granular materials lies within 900 mm (36 inches) of the subgrade, such old road surface shall be scarified to a depth of at least 150 mm (6 inches) whenever directed by the Engineer. This scarified materials shall then be compacted as provided in Subsection 104.3.3.

When shoulder excavation is specified, the roadway shoulders shall be excavated to the depth and width shown on the Plans. The shoulder material shall be removed without disturbing the adjacent existing base course material, and all excess excavated materials shall be disposed off as provided in Subsection 102.2.3. If necessary, the areas shall be compacted before being backfilled.

Roadway embankment of earth material shall be placed in horizontal layers not exceeding 200 mm (8 inches), loose measurement, and shall be compacted as specified before the next layer is placed. However, thicker layer maybe placed if vibratory roller with high compactive effort is used provided that density requirement is attained and as approved by the Engineer. Trial section to this effect must be conducted and approved by the Engineer. Effective spreading equipment shall be used on each lift to obtain uniform thickness as determined in the trial section prior to compaction. As the compaction of each layer progresses, continuous leveling and manipulating will be required to assure uniform density. Water shall be added or removed, if necessary, in order to obtain the required density. Removal of water shall be accomplished through aeration by plowing, blading, discing, or other methods satisfactory to the Engineer.

Where embankment is to be constructed across low swampy ground that will not support the mass of trucks or other hauling equipment, the lower part of the fill may be constructed by dumping successive loads in a uniformly distributed layer of a thickness not greater than necessary to support the hauling equipment while placing subsequent layers.

When excavated material contains more than 25 mass percent of rock larger than 150 mm in greatest diameter and cannot be placed in layers of the thickness prescribed without crushing, pulverizing or further breaking down the pieces resulting from excavation methods, such materials may be placed on the embankment in layers not exceeding in thickness the approximate average size of the larger rocks, but not greater than 600 mm (24 inches).

Even though the thickness of layers is limited as provided above, the placing of individual rocks and boulders greater than 600 mm in diameter will be permitted provided that when placed, they do not exceed 1200 mm (48 inches) in height and provided they are carefully distributed, with the interstices filled with finer material to form a dense and compact mass.

Each layer shall be leveled and smoothed with suitable leveling equipment and by distribution of spalls and finer fragments of earth. Lifts of material containing more than 25 mass percent of rock larger than 150 mm in greatest dimensions shall not be constructed above an elevation 300 mm ( 12 inches) below the finished subgrade. The balance of the embankment shall be composed of suitable material smoothed and placed in layers not exceeding 200 mm (8 inches) in loose thickness and compacted as specified for embankments.

Dumping and rolling areas shall be kept separate, and no lift shall be covered by another until compaction complies with the requirements of Subsection 104.3.3.

Hauling and leveling equipment shall be so routed and distributed over each layer of the fill in such a manner as to make use of compaction effort afforded thereby and to minimize rutting and uneven compaction.

### **104.3.3 Compaction**

#### **Compaction Trials**

Before commencing the formation of embankments, the Contractor shall submit in writing to the Engineer for approval his proposals for the compaction of each type of fill material to be used in the works. The proposals shall include the relationship between the types of compaction equipment, and the number of passes required and the method of adjusting moisture content. The Contractor shall carry out full scale compaction trials on areas not less than 10 m wide and 50 m long as required by the Engineer and using his proposed procedures or such amendments thereto as may be found necessary to satisfy the Engineer that all the specified requirements regarding compaction can be consistently achieved. Compaction trials with the main types of fill material to be used in the works shall be completed before work with the corresponding materials will be allowed to commence.

Throughout the periods when compaction of earthwork is in progress, the Contractor shall adhere to the compaction procedures found from compaction trials for each type of material being compacted, each type of compaction equipment employed and each degree of compaction specified.

#### **Earth**

The Contractor shall compact the material placed in all embankment layers and the material scarified to the designated depth below subgrade in cut sections, until a **uniform density of not less than 95 mass percent of the maximum dry density determined by AASHTO T 99 Method C**, is attained, at a moisture content determined by Engineer to be suitable for such density. Acceptance of compaction may be based on adherence to an approved roller pattern developed as set forth in Item 106, Compaction Equipment and Density Control Strips.

The Engineer shall during progress of the Work, make density tests of compacted material in accordance with AASHTO T 191, T 205, or other approved field density tests, including the use of properly calibrated nuclear testing devices. A correction for coarse particles may be made in accordance with AASHTO T 224. If, by such tests, the Engineer determines that the specified density and moisture conditions have not been attained, the Contractor shall perform additional work as may be necessary to attain the specified conditions.

At least one group of three in-situ density tests shall be carried out for each 500 m of each layer of compacted fill.

## **Rock**

Density requirements will not apply to portions of embankments constructed of materials which cannot be tested in accordance with approved methods.

Embankment materials classified as rock shall be deposited, spread and leveled the full width of the fill with sufficient earth or other fine material so deposited to fill the interstices to produce a dense compact embankment. In addition, one of the rollers, vibrators, or compactors meeting the requirements set forth in Subsection 106.2.1, **Compaction Equipment**, shall compact the embankment full width with a minimum of three complete passes for each layer of embankment.

### **104.3.4 Protection of Roadbed During Construction**

During the construction of the roadway, the roadbed shall be maintained in such condition that it will be well drained at all times. Side ditches or gutters emptying from cuts to embankments or otherwise shall be so constructed as to avoid damage to embankments by erosion.

### **104.3.5 Protection of Structure**

If embankment can be deposited on one side only of abutments, wing walls, piers or culvert headwalls, care shall be taken that the area immediately adjacent to the structure is not compacted to the extent that it will cause overturning of, or excessive pressure against the structure. When noted on the Plans, the fill adjacent to the end bent of a bridge shall not be placed higher than the bottom of the backfill of the bent until the superstructure is in place. When embankment is to be placed on both sides of a concrete wall or box type structure, operations shall be so conducted that the embankment is always at approximately the same elevation on both sides of the structure.

### **104.3.6 Rounding and Warping Slopes**

**Rounding**-Except in solid rock, the tops and bottoms of all slopes, including the slopes of drainage ditches, shall be rounded as indicated on the Plans. A layer of earth overlaying rock shall be rounded above the rock as done in earth slopes.

**Warping**-adjustments in slopes shall be made to avoid injury in standing trees or marring of weathered rock, or to harmonize with existing landscape features, and the transition to such adjusted slopes shall be gradual. At intersections of cuts and fills, slopes shall be adjusted and warped to flow into each other or into the natural ground surfaces without noticeable break.

### **104.3.7 Finishing Roadbed and Slopes**

After the roadbed has been substantially completed, the full width shall be conditioned by removing any soft or other unstable material that will not compact properly or serve the intended purpose. The resulting areas and all other low sections, holes or depressions shall be brought to grade with suitable selected material. Scarifying, blading, dragging, rolling, or other methods of work shall be performed or used as necessary to provide a thoroughly compacted roadbed shaped to the grades and cross-sections shown on the Plans or as staked by the Engineer.

All earth slopes shall be left with roughened surfaces but shall be reasonably uniform, without any noticeable break, and in reasonably close conformity with the Plans or other surfaces indicated on the Plans or as staked by the Engineer, with no variations therefrom readily discernible as viewed from the road.

### **104.3.8 Serrated Slopes**

Cut slopes in rippable material (soft rock) having slope ratios between 0.75:1 and 2:1 shall be constructed so that the final slope line shall consist of a series of small horizontal steps. The step rise and tread dimensions shall be shown on the Plans. No scaling shall be performed on the stepped slopes except for removal of large rocks which will obviously be a safety hazard if they fall into the ditchline or roadway.

### **104.3.9 Earth Berms**

When called for in the Contract, permanent earth berms shall be constructed of well graded materials with no rocks having a diameter greater than 0.25 the height of the berm. When local material is not acceptable, acceptable material shall be imported, as directed by the Engineer.

#### ***Compacted Berm***

Compacted berm construction shall consist of moistening or drying and placing material as necessary in locations shown on the drawings or as established by the Engineer. Material shall contain no frozen material, roots, sod, or other deleterious materials. Contractor shall take precaution to prevent material from escaping over the embankment slope. Shoulder surface beneath berm will be roughened to provide a bond between the berm and shoulder when completed. The Contractor shall compact the material placed until at least 90 mass percent of the maximum density is obtained as determined by AASHTO T 99, Method C. The cross-section of the finished compacted berm shall reasonably conform to the typical cross-section as shown on the Plans.

#### ***Uncompacted Berm***

Uncompacted berm construction shall consist of drying, if necessary and placing material in locations shown on the Plans or as established by the Engineer. Material shall contain no frozen material, roots, sod or other deleterious materials. Contractor shall take precautions to prevent material from escaping over the embankment slope.

#### **104.4 Method of Measurement**

The quantity of embankment to be paid for shall be the volume of material compacted in place, accepted by the Engineer and formed with material obtained from any source.

Material from excavation per Item 102 which is used in embankment and accepted by the Engineer will be paid under Embankment and such payment will be deemed to include the cost of excavating, hauling, stockpiling and all other costs incidental to the work.

Material for Selected Borrow topping will be measured and paid for under the same conditions specified in the preceding paragraph.

#### **104.5 Basis of Payment**

The accepted quantities, measured as prescribed in Section 104.4, shall be paid for at the Contract unit price for each of the Pay Items listed below that is included in the Bill of Quantities. The payment shall continue full compensation for placing and compacting all materials including all labor, equipment, tools and incidentals necessary to complete the work prescribed in this Item.

Payment will be made under:

Pay Item Number	Description	Unit of Measurement
104 (1)	Embankment	Cubic Meter
104 (2)	Selected, Borrow for topping, Case 1	Cubic Meter
104 (3)	Selected Borrow for topping, Case 2	Cubic Meter
104 (4)	Earth Berm	Meter

### **Item 105 – SUBGRADE PREPARATION**

#### **105.1 Description**

This Item shall consist of the preparation of the subgrade for the support of overlying structural layers. It shall extend to full width of the roadway. Unless authorized by the Engineer, subgrade preparation shall not be done unless the Contractor is able to start immediately the construction of the pavement structure.

#### **105.2 Material Requirements**

Unless otherwise stated in the Contract and except when the sub grade is in rock cut, all materials below sub grade level to a depth 150 mm or to such greater depth as may be specified shall meet the requirements of Section 104.2, Selected Borrow for Topping.

#### **105.3 Construction Requirements**

##### **105.3.1 Prior Works**



Prior to commencing preparation of the sub grade, all culverts, cross drains, ducts and the like (including their fully compacted backfill), ditches, drains and drainage outlets shall be completed. Any work on the preparation of the subgrade shall not be started unless prior work herein described shall have been approved by the Engineer.

### 105.3.2 Subgrade Level Tolerances

The finished compacted surface of the subgrade shall conform to the allowable tolerances as specified hereunder:

Permitted variation from design LEVEL OF SURFACE	+ 20 mm
Permitted SURFACE IRREGULARITY MEASURED BY 3-m STRAIGHT EDGE	- 30 mm
Permitted variation from design CROSSFALL OR CAMBER	30 mm
Permitted variation from design LONGITUDINAL GRADE over 25 m length	$\pm$ 0.5 %
	$\pm$ 0.1 %

### 105.3.3 Subgrade in Common Excavation

Unless otherwise specified, all materials below subgrade level in earth cuts to a depth 150 mm or other depth shown on the Plans or as directed by the Engineer shall be excavated. The material, if suitable, shall be set side for future use or, if unsuitable, shall be disposed off in accordance with the requirements of Subsection 102.2.9.

Where material has been removed from below subgrade level, the resulting surface shall be compacted to a depth of 150 mm and in accordance with other requirements of Subsection 104.3.3.

All materials immediately below subgrade level in earth cuts to a depth of 150 mm, or to such greater depth as may be specified, shall be compacted in accordance with the requirements of Subsection 104.3.3.

### 105.3.4 Subgrade in Rock Excavation

Surface irregularities under the subgrade level remaining after trimming of the rock excavation shall be leveled by placing specified material and compacted to the requirements of Subsection 104.3.3.

### 105.3.5 Subgrade on Embankment

After the embankment has been completed, the full width shall be conditioned by removing any soft or other unstable material that will not compacted properly. The resulting areas and all other low sections, holes, or depressions shall be brought to grade with suitable material. The entire roadbed shall be shaped and compacted to the requirements of Subsections 104.3.3. Scarifying, blading, dragging, rolling, or other methods of work shall be performed

or used as necessary to provide a thoroughly compacted roadbed shaped to the cross-sections shown on the Plans.

### **105.3.6 Subgrade on Existing Pavement**

Where the new pavement is to be constructed immediately over an existing Portland Cement concrete pavement and if so specified in the Contract the slab be broken into pieces with greatest dimension of not more than 500 mm and the existing pavement material compacted as specified in Subsection 104.3.3, as directed by the Engineer. The resulting subgrade level shall, as part pavement construction be shaped to conform to the allowable tolerances of Subsection 105.3.2 by placing and compacting where necessary a leveling course comprising the material of the pavement course to be placed immediately above.

Where the new pavement is to be constructed immediately over an existing asphalt concrete pavement or gravel surface pavement and if so specified in the Contract the pavement shall be scarified, thoroughly loosened, reshaped and recompactd in accordance with Subsection 104.3.3. The resulting subgrade level shall conform to the allowable tolerances of Subsection 105.3.2.

### **105.3.7 Protection of Completed Work**

The Contractor shall be required to protect and maintain at his own expense the entire work within the limits of his Contract in good condition satisfactory to the Engineer from the time he first started work until all work shall have been completed. Maintenance shall include repairing and recompactd ruts, ridges, soft spots and deteriorated sections of the subgrade caused by the traffic of the Contractor's vehicle/equipment or that of the public.

### **105.3.8 Templates and Straight-edges**

The Contractor shall provide for use of the Engineer, approved templates and straight-edges in sufficient number to check the accuracy of the work, as provided in this Specification.

## **105.4 Method of Measurement**

### **105.4.1 Measurement of Items for payment shall be provided only for:**

1. The compaction of existing ground below subgrade level in cuts of common material as specified in Subsection 105.3.3.
2. The breaking up or scarifying, loosening, reshaping and recompactd of existing pavement as specified in Subsection 105.3.6. The quantity to be paid for shall be the area of the work specified to be carried out and accepted by the Engineer.

**105.4.2** Payment for all work for the preparation of the subgrade, including shaping to the required levels and tolerances, other than as specified above shall be deemed to be included in the Pay Item for Embankment.

## **105.5 Basis of Payment**

The accepted quantities, measured as prescribed in Section 105.4, shall be paid for at the appropriate contract unit price for Pay Item listed below that is included in the Bill of Quantities which price and payment shall be full compensation for the placing or removal and disposal of all materials including all labor, equipment, tools and incidentals necessary to complete the work prescribed in this Item.

Payment will be made under:

Pay Item Number	Description	Unit of Measurement
105 (1)	Subgrade Preparation (Common Material)	Square Meter
105 (2)	Subgrade Preparation (Existing Pavement)	Square Meter
105 (3)	Subgrade Preparation (Unsuitable Material)	Square Meter

*ITEM 200 – AGGREGATE SUBBASE COURSE*

**200.1 Description**

This item shall consist of furnishing, placing and compacting an aggregate subbase course on a prepared subgrade in accordance with this Specification and the lines, grades and cross-sections shown on the Plans, or as directed by the Engineer.

**200.2 Material Requirements**

Aggregate for subbase shall consist of hard, durable particles or fragments of crushed stone, crushed slag, or crushed or natural gravel and filler of natural or crushed sand or other finely divided mineral matter. The composite material shall be free from vegetable matter and lumps or balls of clay, and shall be of such nature that it can be compacted readily to form a firm, stable subbase.

The subbase material shall conform to Table 200.1, Grading Requirements

**Table 200.1 – Grading Requirements**

Sieve Designation		Mass Percent Passing
Standard, mm	Alternate US Standard	
50	2"	100
25	1"	55 – 85
9.5	3/8"	40 – 75
0.075	No. 200	0 - 12

The fraction passing the 0.075 mm (No. 200) sieve shall not be greater than 0.66 (two thirds) of the fraction passing the 0.425 mm (No. 40) sieve.

The fraction passing the 0.425 mm (No. 40) sieve shall have a liquid limit not greater than 35 and plasticity index not greater than 12 as determined by AASHTO T 89 and T 90, respectively.

The coarse portion, retained on a 2.00 mm (No. 10) sieve, shall have a mass percent of wear not exceeding 50 by the Los Angeles Abrasion Tests as determined by AASHTO T 96.

The material shall have a soaked CBR value of not less than 25% as determined by AASHTO T 193. The CBR value shall be obtained at the maximum dry density and determined by AASHTO T 180, Method D.

### **200.3 Construction Requirements**

#### **200.3.1 Preparation of Existing Surface**

The existing surface shall be graded and finished as provided under Item 105, Subgrade Preparation, before placing the subbase material.

#### **200.3.2 Placing**

The aggregate subbase material shall be placed at a uniform mixture on a prepared subgrade in a quantity which will provide the required compacted thickness. When more than one layer is required, each layer shall be shaped and compacted before the succeeding layer is placed.

The placing of material shall begin at the point designated by the Engineer. Placing shall be from vehicles especially equipped to distribute the material in a continuous uniform layer or windrow. The layer or windrow shall be of such size that when spread and compacted the finished layer be in reasonably close conformity to the nominal thickness shown on the Plans.

When hauling is done over previously placed material, hauling equipment shall be dispersed uniformly over the entire surface of the previously constructed layer, to minimize rutting or uneven compaction.

#### **200.3.3 Spreading and Compacting**

When uniformly mixed, the mixture shall be spread to the plan thickness, for compaction.

Where the required thickness is 150 mm or less, the material may be spread and compacted in one layer. Where the required thickness is more than 150 mm, the aggregate subbase shall be spread and compacted in two or more layers of approximately equal thickness, and the maximum compacted thickness of any layer shall not exceed 150 mm. All subsequent layers shall be spread and compacted in a similar manner.

The moisture content of subbase material shall, if necessary, be adjusted prior to compaction by watering with approved sprinklers mounted on trucks or by drying out, as required in order to obtain the required compaction.

Immediately following final spreading and smoothing, each layer shall be compacted to the full width by means of approved compaction equipment. Rolling shall progress gradually

from the sides to the center, parallel to the centerline of the road and shall continue until the whole surface has been rolled. Any irregularities or depressions that develop shall be corrected by loosening the material at these places and adding or removing material until surface is smooth and uniform. Along curbs, headers, and walls, and at all places not accessible to the roller, the subbase material shall be compacted thoroughly with approved tampers or compactors.

If the layer of subbase material, or part thereof, does not conform to the required finish, the Contractor shall, at his own expense, make the necessary corrections.

Compaction of each layer shall continue until a field density of at least 100 percent of the maximum dry density determined in accordance with AASHTO T 180, Method D has been achieved. In-place density determination shall be made in accordance with AASHTO T 191.

#### **200.3.4 Trial Sections**

Before subbase construction is started, the Contractor shall spread and compact trial sections as directed by the Engineer. The purpose of the trial sections is to check the suitability of the materials and the efficiency of the equipment and construction method which is proposed to be used by the Contractor. Therefore, the Contractor must use the same material, equipment and procedures that he proposes to use for the main work. One trial section of about 500 m<sup>2</sup> shall be made for every type of material and/or construction equipment/procedure proposed for use.

After final compaction of each trial section, the Contractor shall carry out such field density tests and other tests required as directed by the Engineer.

If a trial section shows that the proposed materials, equipment or procedures in the Engineer's opinion are not suitable for subbase, the material shall be removed at the Contractor's expense, and a new trial section shall be constructed.

If the basic conditions regarding the type of material or procedure change during the execution of the work, new trial sections shall be constructed.

#### **200.3.5 Tolerances**

Aggregate subbase shall be spread with equipment that will provide a uniform layer which when compacted will conform to the designed level and transverse slopes as shown on the Plans. The allowable tolerances shall be as specified hereunder:

Permitted variation from design THICKNESS OF LAYER	± 20 mm
Permitted variation from design LEVEL OF SURFACE	+10 mm -20 mm
Permitted SURFACE IRREGULARITY Measured by 3-m straight-edge	20 mm

Permitted variation from design CROSSFALL OR CAMBER	±0.3%
Permitted variation from design LONGITUDINAL GRADE over 25 m in length	±0.1%

**200.4 Method of Measurement**

Aggregate Subbase Course will be measured by the cubic meter (m<sup>3</sup>). The quantity to be paid for shall be the design volume compacted in-place as shown on the Plans, and accepted in the completed course. No allowance will be given for materials placed outside the design limits shown on the cross-sections. Trial sections shall not be measured separately but shall be included in the quantity of subbase herein measured.

**200.5 Basis of Payment**

The accepted quantities, measured as prescribed in Section 200.4, shall be paid for at the contract unit price for Aggregate Subbase Course which price and payment shall be full compensation for furnishings and placing all materials, including all labor, equipment, tools and incidentals necessary to complete the work prescribed in this Item.

Payment will be made under:

Pay Item Number	Description	Unit of Measurement
200	Aggregate Subbase Course	Cubic Meter

**7.2. ITEM 311 – PORTLAND CEMENT CONCRETE PAVEMENT**

**311.1 Description**

This Item shall consist of pavement of Portland Cement Concrete, with or without reinforcement, constructed on the prepared base in accordance with this Specification and in conformity with lines, grades, thickness and typical cross-section shown on the Plans.

**311.2 Material Requirements**

**311.2.1 Portland Cement**

It shall conform to the applicable requirements of Item 700, Hydraulic Cement. Only Type I Portland Cement shall be used unless otherwise provided for in the Special Provisions. Different brands or the same brands from different mills shall not be mixed nor shall they be used alternately unless the mix is approved by the Engineer. However, the use of Portland Pozzolan Cement Type IP meeting the requirements of AASHTO M 240/ASTM C 695, Specifications for Blended Hydraulic Cement shall be allowed, provided that trial mixes shall

be done and that the mixes meet the concrete strength requirements, the AASHTO/ASTM provisions pertinent to the use of Portland Pozzolan Type IP shall be adopted.

Cement which for any reason, has become partially set or which contains lumps of caked cement will be rejected. Cement salvaged from discarded or used bags shall not be used.

Samples of Cement shall be obtained in accordance with AASHTO T 127.

### **311.2.2 Fine Aggregate**

It shall consist of natural sand, stone screenings or other inert materials with similar characteristics, or combinations thereof, having hard, strong and durable particles. Fine aggregate from different sources of supply shall not be mixed or stored in the same pile nor used alternately in the same class of concrete without the approval of the Engineer.

It shall not contain more than three (3) mass percent of material passing the 0.075 mm (No. 200 sieve) by washing nor more than one (1) mass percent each of clay lumps or shale. The use of beach sand will not be allowed without the approval of the Engineer.

If the fine aggregate is subjected to five (5) cycles of the sodium sulfate soundness test, the weighted loss shall not exceed 10 mass percent.

The fine aggregate shall be free from injurious amounts of organic impurities. If subjected to the colorimatic test for organic impurities and a color darker than the standard is produced, it shall be rejected. However, when tested for the effect of organic impurities of strength of mortar by AASHTO T 71, the fine aggregate may be used if the relative strength at 7 and 28 days is not less than 95 mass percent.

The fine aggregate shall be well-graded from coarse to fine and shall conform to Table 311.1

**Table 311.1 – Grading Requirements for Fine Aggregate**

Sieve Designation	Mass Percent Passing
9.5 mm (3/8 in)	100
4.75 mm (No. 4)	95 – 100
2.36 mm (No. 8)	-
1.18 mm (No. 16)	45 – 80
0.600 mm (No. 30)	-
0.300 mm (No. 50)	5 – 30
0.150 mm (No. 100)	0 – 10

### **311.2.3 Coarse Aggregate**

It shall consist of crushed stone, gravel, blast furnace slag, or other approved inert materials of similar characteristics, or combinations thereof, having hard, strong, durable pieces and free from any adherent coatings.

It shall contain not more than one (1) mass percent of material passing the 0.075 mm (No. 200) sieve, not more than 0.25 mass percent of clay lumps, nor more than 3.5 mass percent of soft fragments.

If the coarse aggregate is subjected to five (5) cycles of the sodium sulfate soundness test, the weighted loss shall not exceed 12 mass percent.

It shall have a mass percent of wear not exceeding 40 when tested by AASHTO T 96.

If the slag is used, its density shall not be less than 1120 kg/m<sup>3</sup> (70 lb./cu. ft.). The gradation of the coarse aggregate shall conform to Table 311.2.

Only one grading specification shall be used from any one source.

**Table 311.2 – Grading Requirement for Coarse Aggregate**

Sieve Designation		Mass Percent Passing		
Standard Mm	Alternate U. S. Standard	Grading A	Grading B	Grading C
75.00	3 in.	100	-	-
63.00	2-1/2 in.	90-100	100	100
50.00	2 in.	-	90-100	95-100
37.5	1-1/2 in.	25-60	35-70	-
25.0	1 in.	-	0-15	35-70
19.0	¾ in.	0-10	-	-
12.5	½ in.	0-5	0-5	10-30
4.75	No. 4	-	-	0-5

#### **311.2.4 Water**

Water used in mixing, curing or other designated application shall be reasonably clean and free of oil, salt, acid, alkali, grass or other substances injurious to the finished product. Water will be tested in accordance with and shall meet the requirements of Item 714, Water. Water which is drinkable may be used without test. Where the source of water is shallow, the intake shall be so enclosed as to exclude silt, mud, grass or other foreign materials.

#### **311.2.5 Reinforcing Steel**

It shall conform to the requirements of Item 404, Reinforcing Steel. Dowels and tie bars shall conform to the requirements of AASHTO M 31 or M 42, except that rail steel shall not be used for tie bars that are to be bent and restrengthened during construction. Tie bars shall be deformed bars. Dowels shall be plain round bars. Before delivery to the site of work, one-half of the length of each dowel shall be painted with one coat of approved lead or tar paint.

The sleeves for dowel bars shall be metal of approved design to cover 50 mm ( 2 inches), plus or minus 5 mm (1/4 inch) of the dowel, with a closed end, and with a suitable stop



to hold the end of the sleeve at least 25 mm (1 inch) from the end of the dowel. Sleeves shall be of such design that they do not collapse during construction.

### **311.2.6 Joint Fillers**

Poured joint fillers shall be mixed asphalt and mineral or rubber filler conforming to the applicable requirements of Item 705, Joint Materials.

Preformed joint filler shall conform to the applicable requirements of Item 705. It shall be punched to admit the dowels where called for in the Plans. The filler for each joint shall be furnished in a single piece for the full depth and width required for the joint.

### **311.2.7 Admixtures**

Air-entraining admixture shall conform to the requirements of AASHTO M 154.

Chemical admixtures, if specified or permitted, shall conform to the requirements of AASHTO M 194.

Fly Ash, if specified or permitted as a mineral admixture and as 20% partial replacement of Portland Cement in concrete mix shall conform to the requirements of ASTM C 618.

Admixture should be added only to the concrete mix to produce some desired modifications to the properties of concrete where necessary, but not as partial replacement of cement.

### **311.2.8 Curing Materials**

Curing materials shall conform to the following requirements as specified;

- |                                      |                |
|--------------------------------------|----------------|
| a) Burlap cloth                      | - AASHTO M 182 |
| b) Liquid membrane forming compounds | - AASHTO M 148 |
| c) Sheeting (film) materials         | - AASHTO M 171 |

Cotton mats and water-proof paper can be used.

### **311.2.9 Calcium Chloride/Calcium Nitrate**

It shall conform to AASHTO M 144, if specified or permitted by the Engineer, as accelerator.

### **311.2.10 Storage of Cement and Aggregate**

All cement shall be stored, immediately upon delivery at the Site, in weatherproof building which will protect the cement from dampness. The floor shall be raised from the ground. The buildings shall be placed in locations approved by the Engineer. Provisions for storage shall be ample, and the shipments of cement as received shall be separately stored in such a manner as to allow the earliest deliveries to be used first and to provide easy access for identification and inspection of each shipment. Storage buildings shall have capacity for storage of a sufficient quantity of cement to allow sampling at least twelve (12) days before the cement is

to be used. Bulk cement, if used, shall be transferred to elevated air tight and weatherproof bins. Stored cement shall meet the test requirements at any time after storage when retest is ordered by the Engineer. At the time of use, all cement shall be free-flowing and free of lumps.

The handling and storing of concrete aggregates shall be such as to prevent segregation or the inclusion of foreign materials. The Engineer may require that aggregates be stored on separate platforms at satisfactory locations.

In order to secure greater uniformity of concrete mix, the Engineer may require that the coarse aggregate be separated into two or more sizes. Different sizes of aggregate shall be stored in separate bins or in separate stockpiles sufficiently removed from each other to prevent the material at the edges of the piles from becoming intermixed.

### **311.2.11 Proportioning, Consistency and Strength of Concrete**

The Contractor shall prepare the design mix based on the absolute volume method as outlined in the American Concrete Institute (ACI) Standard 211.1, "Recommended Practice for Selecting Proportions for Normal and Heavyweight Concrete".

It is the intent of this Specification to require at least 364 kg of cement per cubic meter of concrete to meet the minimum strength requirements. The Engineer shall determine from laboratory tests of the materials to be used, the cement content and the proportions of aggregate and water that will produce workable concrete having a slump of between 40 and 75 mm (1-1/2 and 3 inches) if not vibrated or between 10 and 40 mm (1/2 and 1-1/2 inches) if vibrated, and a flexural strength of not less than 3.8 MPa (550 psi) when tested by the third-point method or 4.5 MPa (650 psi) when tested by the mid-point method at fourteen (14) days in accordance with AASHTO T97 and T177, respectively; or a compressive strength of 24.1 MPa (3500 psi) for cores taken at fourteen (14) days and tested in accordance with AASHTO T24.

Slump shall be determined using AASHTO T 119.

The designer shall consider the use of lean concrete (econocrete) mixtures using local materials or specifically modified conventional concrete mixes in base course and in the lower course composite, monolithic concrete pavements using a minimum of 75 mm (3 inches) of conventional concrete as the surface course.

The mix design shall be submitted to the Engineer for approval and shall be accompanied with certified test data from an approved laboratory demonstrating the adequacy of the mix design. A change in the source of materials during the progress of work may necessitate a new design mix.

### **311.3 Construction Requirements**

#### **311.3.1 Quality Control of Concrete**

##### **1. General**

The Contractor shall be responsible for the quality control of all materials during the handling, blending, and mixing and placement operations.

## 2. Quality Control Plan

The Contractor shall furnish the Engineer a Quality Control Plan detailing his production control procedures and the type and frequency of sampling and testing to insure that the concrete produces complies with the Specifications. The Engineer shall be provided free access to recent plant production records, and if requested, informational copies of mix design, materials certifications and sampling and testing reports.

## 3. Qualification of Workmen

Experienced and qualified personnel shall perform all batching or mixing operation for the concrete mix, and shall be present at the plant and job site to control the concrete productions whenever the plant is in operation. They shall be identified and duties defined as follows:

a. Concrete Batcher. The person performing the batching or mixing operation shall be capable of accurately conducting aggregate surface moisture determination and establishing correct scale weights for concrete materials. He shall be capable of assuring that the proportioned batch weights of materials are in accordance with the mix design.

b. Concrete Technician. The person responsible for concrete production control and sampling and testing for quality control shall be proficient in concrete technology and shall have a sound knowledge of the Specifications as they relate to concrete production. He shall be capable of conducting tests on concrete and concrete materials in accordance with these Specifications. He shall be capable of adjusting concrete mix designs for improving workability and Specification compliance and preparing trial mix designs. He shall be qualified to act as the concrete batcher in the batcher's absence.

## 4. Quality Control Testing

The Contractor shall perform all sampling, testing and inspection necessary to assure quality control of the component materials and the concrete.

The Contractor shall be responsible for determining the gradation of fine and coarse aggregates and for testing the concrete mixture for slump, air content, water-cement ratio and temperature. He shall conduct his operations so as to produce a mix conforming to the approved mix design.

## 5. Documentation

The Contractor shall maintain adequate records of all inspections and tests. The records shall indicate the nature and number of observations made, the number and type of deficiencies found, the quantities approved and rejected, and nature of any corrective action taken.

The Engineer may take independent assurance samples at random location for acceptance purposes as he deems necessary.

### **311.3.2 Equipment**

Equipment and tools necessary for handling materials and performing all parts of the work shall be approved by the Engineer as to design, capacity and mechanical condition. The equipment shall be at the jobsite sufficiently ahead of the start of construction operations to be examined thoroughly and approved.

1. Batching Plant and Equipment

a. General. The batching shall include bins, weighing hoppers, and scales for the fine aggregate and for each size of coarse aggregate. If cement is used in bulk, a bin, a hopper, and separate scale for cement shall be included. The weighing hopper shall be properly sealed and vented to preclude dusting operation. The batch plant shall be equipped with a suitable non-resettable batch counter which will correctly indicate the number of batches proportioned.

b. Bins and Hoppers. Bins with adequate separate compartments for fine aggregate and for each size of coarse aggregate shall be provided in the batching plant.

c. Scales. Scales for weighing aggregates and cement shall be of either the beam type or the springless-dial type. They shall be accurate within one-half percent (0.5%) throughout the range of use. Poises shall be designed to be locked in any position and to prevent unauthorized change.

Scales shall be inspected and sealed as often as the Engineer may deem necessary to assure their continued accuracy.

d. Automatic Weighing Devices. Unless otherwise allowed on the Contract, batching plants shall be equipped with automatic weighing devices of an approved type to proportion aggregates and bulk cement.

2. Mixers.

a. General. Concrete may be mixed at the Site of construction or at a central plant, or wholly or in part in truck mixers. Each mixer shall have a manufacturer's plate attached in a prominent place showing the capacity of the drum in terms of volume of mixed concrete and the speed of rotation of the mixing drum or blades.

b. Mixers at Site of Construction. Mixing shall be done in an approved mixer capable of combining the aggregates, cement and water into a thoroughly mixed and uniform mass within the specified mixing period and discharging and distributing the mixture without segregation on the prepared grade. The mixer shall be equipped with an approved timing device which will automatically lock the discharge lever when the drum has been charged and released it at the end of the mixing period. In case of failure of the timing device, the mixer may be used for the balance of the day while it is being repaired, provided that each batch is mixed 90 seconds. The mixer shall be equipped with a suitable nonresettable batch counter which shall correctly indicate the number of the batches mixed.

c. Truck Mixer and Truck Agitators. Truck mixers used for mixing and hauling concrete, and truck agitators used for hauling central-mixed concrete, shall conform to the requirements of AASHTO M 157.

d. Non-Agitator Truck. Bodies of non-agitating hauling equipment for concrete shall be smooth, mortar-tight metal containers and shall be capable of discharging the concrete at a satisfactory controlled rate without segregation.

### 3. Paving and Finishing Equipment

The concrete shall be placed with an approved paver designed to spread, consolidate, screed and float finish the freshly placed concrete in one complete pass of the machine in such a manner that a minimum of hand finishing will be necessary to provide a dense and homogeneous pavement in conformance with the Plans and Specifications.

The finishing machine shall be equipped with at least two (2) oscillating type transverse screed.

Vibrators shall operate at a frequency of 8,300 to 9,600 impulses per minute under load at a maximum spacing of 60 cm.

### 4. Concrete Saw

The Contractor shall provide sawing equipment in adequate number of units and power to complete the sawing with a water-cooled diamond edge saw blade or an abrasive wheel to the required dimensions and at the required rate. He shall provide at least one (1) stand-by saw in good working condition and with an ample supply of saw blades.

### 5. Forms

Forms shall be of steel, of an approved section, and of depth equal to the thickness of the pavement at the edge. The base of the forms shall be of sufficient width to provide necessary stability in all directions. The flange braces must extend outward on the base to not less than  $\frac{2}{3}$  the height of the form.

All forms shall be rigidly supported on bed of thoroughly compacted material during the entire operation of placing and finishing the concrete. Forms shall be provided with adequate devices for secure setting so that when in place, they will withstand, without visible spring or settlement, the impact and vibration of the consolidation and finishing or paving equipment.

#### **311.3.3 Preparation of Grade**

After the subgrade of base has been placed and compacted to the required density, the areas which will support the paving machine and the grade on which the pavement is to be constructed shall be trimmed to the proper elevation by means of a properly designed machine extending the prepared work areas compacted at least 60 cm beyond each edge of the proposed concrete pavement. If loss of density results from the trimming operations, it shall be restored by additional compaction before concrete is placed. If any traffic is allowed to use the prepared subgrade or base, the surface shall be checked and corrected immediately ahead of the placing concrete.

The subgrade or base shall be uniformly moist when the concrete is placed.

### **311.3.4 Setting Forms**

#### **1. Base Support.**

The foundation under the forms shall be hard and true to grade so that the form when set will be firmly in contact for its whole length and at the specified grade. (Any roadbed, which at the form line is found below established grade, shall be filled with approved granular materials to grade in lifts of three (3) cm or less, and thoroughly rerolled or tamped.) Imperfections or variations above grade shall be corrected by tamping or by cutting as necessary.

#### **2. Form Setting**

Forms shall be set sufficiently in advance of the point where concrete is being placed. After the forms have been set to correct grade, the grade shall be thoroughly tamped, mechanically or by hand, at both the inside and outside edges of the base of the forms. The forms shall not deviate from true line by more than one (1) cm at any point.

#### **3. Grade and Alignment**

The alignment and grade elevations of the forms shall be checked and corrections made by the Contractor immediately before placing the concrete. Testing as to crown and elevation, prior to placing of concrete can be made by means of holding an approved template in a vertical position and moved backward and forward on the forms.

When any form has been disturbed or any grade has become unstable, the form shall be reset and rechecked.

### **311.3.5 Conditioning of Subgrade or Base Course**

When side forms have been securely set to grade, the subgrade or base course shall be brought to proper cross-section. High areas shall be trimmed to proper elevation. Low areas shall be filled and compacted to a condition similar to that of surrounding grade. The finished grade shall be maintained in a smooth and compacted condition until the pavement is placed.

Unless waterproof subgrade or base course cover material is specified, the subgrade or base course shall be uniformly moist when the concrete is placed. If it subsequently becomes too dry, the subgrade or base course shall be sprinkled, but the method of sprinkling shall not be such as to form mud or pools of water.

### **311.3.6 Handling, Measuring and Batching Materials**

The batch plant site, layout, equipment and provisions for transporting material shall be such as to assure a continuous supply of material to the work.

Stockpiles shall be built up in layers of not more than one (1) meter in thickness. Each layer shall be completely in place before beginning the next which shall not be allowed to "cone" down over the next lower layer. Aggregates from different sources and of different grading shall not be stockpiled together.

All washed aggregates and aggregates produced or handled by hydraulic methods, shall be stockpiled or binned for draining at least twelve (12) hours before being batched.

When mixing is done at the side of the work, aggregates shall be transported from the batching plant to the mixer in batch boxes, vehicle bodies, or other containers of adequate capacity and construction to properly carry the volume required. Partitions separating batches shall be adequate and effective to prevent spilling from one compartment to another while in transit or being dumped. When bulk cement is used, the Contractor shall use a suitable method of handling the cement from weighing hopper to transporting container or into the batch itself for transportation to the mixer, with chute, boot or other approved device, to prevent loss of cement, and to provide positive assurance of the actual presence in each batch of the entire cement content specified.

Bulk cement shall be transported to the mixer in tight compartments carrying the full amount of cement required for the batch. However, if allowed in the Special Provisions, it may be transported between the fine and coarse aggregate. When cement is placed in contact with the aggregates, batches may be rejected unless mixed within 1-1/2 hours of such contact. Cement in original shipping packages may be transported on top of the aggregates, each batch containing the number of sacks required by the job mix.

The mixer shall be charged without loss of cement. Batching shall be so conducted as to result in the weight to each material required within a tolerance of one (1) percent for the cement and two (2) percent for aggregates.

Water may be measured either by volume or by weight. The accuracy of measuring the water shall be within a range of error of not over than one (1) percent. Unless the water is to be weighed, the water-measuring equipment shall include an auxiliary tank from which the measuring tank shall be equipped with an outside tap and valve to provide checking the setting, unless other means are provided for readily and accurately determining the amount of water in the tank. The volume of the auxiliary tank shall be at least equal to that of the measuring tank.

### **311.3.7      Mixing Concrete**

The concrete may be mixed at the site of the work in a central-mix plant, or in truck mixers. The mixer shall be of an approved type and capacity. Mixing time will be measured from the time all materials, except water, are in the drum. Ready-mixed concrete shall be mixed and delivered in accordance with requirements of AASHTO M 157, except that the minimum required revolutions at the mixing speed for transit-mixed concrete may be reduced to not less than that recommended by the mixer manufacturer. The number of revolutions recommended by the mixer manufacturer shall be indicated on the manufacturer's serial plate attached to the mixer. The Contractor shall furnish test data acceptable to the Engineer verifying that the make and model of the mixer will produce uniform concrete conforming to the provision of AASHTO M 157 at the reduced number of revolutions shown on the serial plate.

When mixed at the site or in a central mixing plant, the mixing time shall not be less than fifty (50) seconds nor more than ninety (90) seconds, unless mixer performance tests prove adequate mixing of the concrete is a shorter time period.

Four (4) seconds shall be added to the specified mixing time if timing starts at the instant the skip reaches its maximum raised positions. Mixing time ends when the discharge chute opens. Transfer time in multiple drum mixers is included in mixing time. The contents of an individual mixer drum shall be removed before a succeeding batch is emptied therein.

The mixer shall be operated at the drum speed as shown on the manufacturer's name plate attached on the mixer. Any concrete mixed less than the specified time shall be discarded and disposed off by the Contractor at his expense. The volume of concrete mixed per batch shall not exceed the mixer's nominal capacity in cubic meter, as shown on the manufacturer's standard rating plate on the mixer, except that an overload up to ten (10) percent above the mixer's nominal capacity may be permitted provided concrete test data for strength, segregation, and uniform consistency are satisfactory, and provided no spillage of concrete takes place.

The batches shall be so charged into the drum that a portion of the mixing water shall be entered in advance of the cement and aggregates. The flow of water shall be uniform and all water shall be in the drum by the end of the first fifteen (15) seconds of the mixing period. The throat of the drum shall be kept free of such accumulations as may restrict the free flow of materials into the drum.

Mixed concrete from the central mixing plant shall be transported in truck mixers, truck agitators or non-agitating truck specified in Subsection 311.3.2, Equipment. The time elapsed from the time water is added to the mix until the concrete is deposited in place at the Site shall not exceed forty five (45) minutes when the concrete is hauled in non-agitating trucks, nor ninety (90) minutes when hauled in truck mixers or truck agitators, except that in hot weather or under other conditions contributing to quick hardening of the concrete, the maximum allowable time may be reduced by the Engineer.

In exceptional cases and when volumetric measurements are authorized for small project requiring less than 75 cu.m. of concrete per day of pouring, the weight proportions shall be converted to equivalent volumetric proportions. In such cases, suitable allowance shall be made for variations in the moisture condition of the aggregates, including the bulking effect in the fine aggregate. Batching and mixing shall be in accordance with ASTM C 685, Section 6 through 9.

Concrete mixing by chute is allowed provided that a weighing scales for determining the batch weight will be used.

Retempering concrete by adding water or by other means shall not be permitted, except that when concrete is delivered in truck mixers, additional water may be added to the batch materials and additional mixing performed to increase the slump to meet the specified requirements, if permitted by the Engineer, provided all these operations are performed within forty-five (45) minutes after the initial mixing operation and the water-cement ratio is not exceeded. Concrete that is not within the specified slump limits at the time of placement shall not be used. Admixtures for increasing the workability or for accelerating the setting of the concrete will be permitted only when specifically approved by the Engineer.

### **311.3.8      Limitation of Mixing**



No concrete shall be mixed, placed or finished when natural light is insufficient, unless an adequate and approved artificial lighting system is operated.

During hot weather, the Engineer shall require that steps be taken to prevent the temperature of mixed concrete from exceeding a maximum temperature of 90<sup>0</sup>F ( 32<sup>0</sup>C)

Concrete not in place within ninety (90) minutes from the time the ingredients were charged into the mixing drum or that has developed initial set shall not be used. Retempering of concrete or mortar which has partially hardened, that is remixing with or without additional cement, aggregate, or water, shall not be permitted.

In order that the concrete may be properly protected against the effects of rain before the concrete is sufficiently hardened, the Contractor will be required to have available at all times materials for the protection of the edges and surface of the unhardened concrete.

### **311.3.9 Placing Concrete**

Concrete shall be deposited in such a manner to require minimal rehandling. Unless truck mixers or non-agitating hauling equipment are equipped with means to discharge concrete without segregation of the materials, the concrete shall be unloaded into an approved spreading device and mechanically spread on the grade in such a manner as to prevent segregation. Placing shall be continuous between transverse joints without the use of intermediate bulkheads. Necessary hand spreading shall be done with shovels, not rakes. Workmen shall not be allowed to walk in the freshly mixed concrete with boots or shoes coated with earth or foreign substances.

When concrete is to be placed adjoining a previously constructed lane and mechanical equipment will be operated upon the existing lane, that previously constructed lane shall have attained the strength for fourteen (14) day concrete. If only finishing equipment is carried on the existing lane, paving in adjoining lanes may be permitted after three (3) days.

Concrete shall be thoroughly consolidated against and along the faces of all forms and along the full length and on both sides of all joint assemblies, by means of vibrators inserted in the concrete. Vibrators shall not be permitted to come in contact with a joint assembly, the grade, or a side form. In no case shall the vibrator be operated longer than fifteen (15) seconds in any one location.

Concrete shall be deposited as near as possible to the expansion and contraction joints without disturbing them, but shall not be dumped from the discharge bucket or hopper into a joint assembly unless the hopper is well centered on the joint assembly. Should any concrete material fall on or be worked into the surface of a complete slab, it shall be removed immediately.

### **311.3.10 Test Specimens**

As work progresses, at least one (1) set consisting of three (3) concrete beam test specimens, 150 mm x 150 mm x 525 mm or 900 mm shall be taken from each 330 m<sup>2</sup> of pavement, 230 mm depth, or fraction thereof placed each day. Test specimens shall be made under the supervision of the Engineer, and the Contractor shall provide all concrete and other facilities

necessary in making the test specimens and shall protect them from damage by construction operations. Cylinder samples shall not be used as substitute for determining the adequacy of the strength of concrete.

The beams shall be made, cured, and tested in accordance with AASHTO T 23 and T 97.

### **311.3.11 Strike-off of Concrete and Placement of Reinforcement**

Following the placing of the concrete, it shall be struck off to conform to the cross-section shown on the Plans and to an elevation such that when the concrete is properly consolidated and finished, the surface of the pavement will be at the elevation shown on the Plans. When reinforced concrete pavement is placed in two (2) layers, the bottom layer shall be struck off and consolidated to such length and depth that the sheet of fabric or bar mat may be laid full length on the concrete in its final position without further manipulation. The reinforcement shall then be placed directly upon the concrete, after which the top layer of the concrete shall be placed, struck off and screeded. Any portion of the bottom layer of concrete which has been placed more than 30 minutes without being covered with the top layer shall be removed and replaced with freshly mixed concrete at the Contractor's expense. When reinforced concrete is placed in one layer, the reinforcement may be firmly positioned in advance of concrete placement or it may be placed at the depth shown on the Plans in plastic concrete, after spreading by mechanical or vibratory means.

Reinforcing steel shall be free from dirt, oil, paint, grease, mill scale and loose or thick rust which could impair bond of the steel with the concrete.

### **311.3.12 Joints**

Joints shall be constructed of the type and dimensions, and at the locations required by the Plans or Special Provisions. All joints shall be protected from the intrusion of injurious foreign material until sealed.

#### **1. Longitudinal Joint**

Deformed steel tie bars of specified length, size, spacing and materials shall be placed perpendicular to the longitudinal joints, they shall be placed by approved mechanical equipment or rigidly secured by chair or other approved supports to prevent displacement. Tie bars shall not be painted or coated with asphalt or other materials or enclosed in tubes or sleeves. When shown on the Plans and when adjacent lanes of pavement are constructed separately, steel side forms shall be used which will form a keyway along the construction joint. Tie bars, except those made of rail steel, may be bent at right angles against the form of the first lane constructed and straightened into final position before the concrete of the adjacent lane is placed, or in lieu of bent tie bars, approved two-piece connectors may be used.

Longitudinal formed joints shall consist of a groove or cleft, extending downward from and normal to, the surface of the pavement. These joints shall be effected or formed by an approved mechanically or manually operated device to the dimensions and line indicated on the Plans and while the concrete is in a plastic state. The groove or cleft shall be filled with either a premolded strip or poured material as required.

The longitudinal joints shall be continuous, there shall be no gaps in either transverse or longitudinal joints at the intersection of the joints.

Longitudinal sawed joints shall be cut by means of approved concrete saws to the depth, width and line shown on the Plans. Suitable guide lines or devices shall be used to assure cutting the longitudinal joint on the true line. The longitudinal joint shall be sawed before the end of the curing period or shortly thereafter and before any equipment or vehicles are allowed on the pavement. The sawed area shall be thoroughly cleaned and, if required, the joint shall immediately be filled with sealer.

Longitudinal pavement insert type joints shall be formed by placing a continuous strip of plastic materials which will not react adversely with the chemical constituent of the concrete.

## 2. Transverse Expansion Joint

The expansion joint filler shall be continuous from form to form, shaped to subgrade and to the keyway along the form. Preformed joint filler shall be furnished in lengths equal to the pavement width or equal to the width of one lane. Damaged or repaired joint filler shall not be used.

The expansion joint filler shall be held in a vertical position. An approved installing bar, or other device, shall be used if required to secure preformed expansion joint filler at the proper grade and alignment during placing and finishing of the concrete. Finished joint shall not deviate more than 6 mm from a straight line. If joint fillers are assembled in sections, there shall be no offsets between adjacent units. No plugs of concrete shall be permitted anywhere within the expansion space.

## 3. Transverse Contraction Joint/Weakened Joint

When shown on the Plans, it shall consist of planes of weakness created by forming or cutting grooves in the surface of the pavement and shall include load transfer assemblies. The depth of the weakened plane joint should at all times not be less than 50 mm, while the width should not be more than 6 mm.

a. Transverse Strip Contraction Joint. It shall be formed by installing a parting strip to be left in place as shown on the Plans.

b. Formed Groove. It shall be made by depressing an approved tool or device into the plastic concrete. The tool or device shall remain in place at least until the concrete has attained its initial set and shall then be removed without disturbing the adjacent concrete, unless the device is designed to remain in the joint.

c. Sawed Contraction Joint. It shall be created by sawing grooves in the surface of the pavement of the width not more than 6 mm, depth should at all times not be less than 50 mm, and at the spacing and lines shown on the Plans, with an approved concrete saw. After each joint is sawed, it shall be thoroughly cleaned including the adjacent concrete surface.

Sawing of the joint shall commence as soon as the concrete has hardened sufficiently to permit sawing without excessive raveling, usually 4 to 24 hours. All joints shall be sawed

before uncontrolled shrinkage cracking takes place. If necessary, the sawing operations shall be carried on during the day or night, regardless of weather conditions. The sawing of any joint shall be omitted if crack occurs at or near the joint location prior to the time of sawing. Sawing shall be discontinued when a crack develops ahead of the saw. In general, all joints should be sawed in sequence. If extreme condition exist which make it impractical to prevent erratic cracking by early sawing, the contraction joint groove shall be formed prior to initial set of concrete as provided above.

#### 4. Transverse Construction Joint

It shall be constructed when there is an interruption of more than 30 minutes in the concreting operations. No transverse joint shall be constructed within 1.50 m of an expansion joint, contraction joint, or plane of weakness. If sufficient concrete has been mixed at the time of interruption to form a slab of at least 1.5 m long, the excess concrete from the last preceding joint shall be removed and disposed off as directed.

#### 5. Load Transfer Device

Dowel, when used, shall be held in position parallel to the surface and center line of the slab by a metal device that is left in the pavement.

The portion of each dowel painted with one coat of lead or tar, in conformance with the requirements of Item 404, Reinforcing Steel, shall be thoroughly coated with approved bituminous materials, e.g., MC-70, or an approved lubricant, to prevent the concrete from binding to that portion of the dowel. The sleeves for dowels shall be metal designed to cover 50 mm plus or minus 5 mm (1/4 inch), of the dowel, with a watertight closed end and with a suitable stop to hold the end of the sleeves at least 25 mm (1 inch) from the end of the dowel.

In lieu of using dowel assemblies at contraction joints, dowel may be placed in the full thickness of pavement by a mechanical device approved by the Engineer.

### **311.3.13 Final Strike-off (Consolidation and Finishing)**

#### 1. Sequence

The sequence of operations shall be the strike-off and consolidation, floating and removal of laitance, straight-edging and final surface finish. Work bridges or other devices necessary to provide access to the pavement surface for the purpose of finishing straight-edging, and make corrections as hereinafter specified, shall be provided by the Contractor.

In general, the addition of water to the surface of the concrete to assist in finishing operations will not be permitted. If the application of water to the surface is permitted, it shall be applied as fog spray by means of an approved spray equipment.

#### 2. Finishing Joints

The concrete adjacent to joints shall be compacted or firmly placed without voids or segregation against the joint material assembly, also under and around all load transfer devices, joint assembly units, and other features designed to extend into the pavement. Concrete

adjacent to joints shall be mechanically vibrated as required in Subsection 311.3.9, Placing Concrete.

After the concrete has been placed and vibrated adjacent to the joints as required in Subsection 311.3.9, the finishing machine shall be brought forward, operating in a manner to avoid damage or misalignment of joints. If uninterrupted operation of the finishing machine, to over and beyond the joints causes segregation of concrete, damage to, or misalignment of the joints, the finishing machine shall be stopped when the front screed is approximately 20 cm (8 inches) from the joint. Segregated concrete shall be removed from in front of and off the joint. The front screed shall be lifted and set directly on top of the joint and the forward motion of the finishing machine resumed. When the second screed is close enough to permit the excess mortar in front of it to flow over the joint, it shall be lifted and carried over the joint. Thereafter, the finishing machine may be run over the joint without lifting the screeds, provided there is no segregated concrete immediately between the joint and the screed or on top of the joint.

### 3. Machine Finishing

a. Non-vibratory Method. The concrete shall be distributed or spread as soon as placed. As soon as the concrete has been placed, it shall be struck off and screeded by an approved finishing machine. The machine shall go over each area of pavement as many times and at such intervals as necessary to give the proper compaction and leave a surface of uniform texture. Excessive operation over a given area shall be avoided. The tops of the forms shall be kept clean by an effective device attached to the machine and the travel of the machine on the forms shall be maintained true without wobbling or other variation tending to affect the precision finish.

During the first pass of the finishing machine, a uniform ridge of concrete shall be maintained ahead of the front screed in its entire length.

b. Vibratory Method. When vibration is specified, vibrators for full width vibration of concrete paving slabs, shall meet the requirements in Subsection 311.3.2, Equipment. If uniform and satisfactory density of the concrete is not obtained by the vibratory method at joints, along forms, at structures, and throughout the pavement, the Contractor will be required to furnish equipment and method which will produce pavement conforming to the Specifications. All provisions in item (a) above not in conflict with the provisions for the vibratory method shall govern.

### 4. Hand Finishing

Hand finishing methods may only be used under the following conditions:

a. In the event of breakdown of the mechanical equipment, hand methods may be used to finish the concrete already deposited on the grade.

b. In narrow widths or areas of irregular dimensions where operations of the mechanical equipment is impractical, hand methods may be used.

Concrete, as soon as placed, shall be struck off and screeded. An approved portable screed shall be used. A second screed shall be provided for striking off the bottom layer of concrete if reinforcement is used.

The screed for the surface shall be at least 60 cm (2 feet) longer than the maximum width of the slab to be struck off. It shall be of approved design, sufficiently rigid to retain its shape, and constructed either of metal or other suitable material shod with metal.

Consolidation shall be attained by the use of suitable vibrator or other approved equipment.

In operation, the screed shall be moved forward on the forms with a combined longitudinal and transverse shearing motion, moving always in the direction in which the work is progressing and so manipulated that neither end is raised from the side forms during the striking off process. If necessary, this shall be repeated until the surface is of uniform texture, true to grade and cross-section, and free from porous areas.

## 5. Floating

After the concrete has been struck off and consolidated, it shall be further smoothed, trued, and consolidated by means of a longitudinal float, either by hand or mechanical method.

a. Hand Method. The hand-operated longitudinal float shall be not less than 365 cm (12 feet) in length and 15 cm (6 inches) in width, properly stiffened to prevent flexibility and warping. The longitudinal float, operated from foot bridges resting on the side forms and spanning but not touching the concrete, shall be worked with a sawing motion while held in a floating position parallel to the road center line, and moving gradually from one side of the pavement to the other. Movement ahead along the center line of the pavement shall be in successive advances of not more than one-half the length of the float. Any excess water or soupy material shall be wasted over the side forms on each pass.

b. Mechanical Method. The mechanical longitudinal float shall be of a design approved by the Engineer, and shall be in good working condition. The tracks from which the float operates shall be accurately adjusted to the required crown. The float shall be accurately adjusted and coordinated with the adjustment of the transverse finishing machine so that a small amount of mortar is carried ahead of the float at all times. The forward screed shall be adjusted so that the float will lap the distance specified by the Engineer on each transverse trip. The float shall pass over each areas of pavement at least two times, but excessive operation over a given area will not be permitted. Any excess water or soupy material shall be wasted over the side forms on each pass.

c. Alternative Mechanical Method. As an alternative, the Contractor may use a machine composed of a cutting and smoothing float or floats suspended from and guided by a rigid frame. The frame shall be carried by four or more visible wheels riding on, and constantly in contact with the side forms. If necessary, following one of the preceding method of floating, long handled floats having blades not less than 150 cm (5 feet) in length and 15 cm (6 inches) in width may be used to smooth and fill in open-textured areas in the pavement. Long-handled floats shall not be used to float the entire surface of the pavement in lieu of, or supplementing, one of the preceding methods of floating. When strike off and consolidation are done by the hand method and the crown of the pavement will not permit the use of the longitudinal float,

the surface shall be floated transversely by means of the long-handled float. Care shall be taken not to work the crown out of the pavement during the operation. After floating, any excess water and laitance shall be removed from the surface of the pavement by a 3-m straight-edge or more in length. Successive drags shall be lapped one-half the length of the blade.

#### 6. Straight-edge Testing and Surface Correction

After the floating has been completed and the excess water removed, but while the concrete is still plastic, the surface of the concrete shall be tested for trueness with a 300 cm long straight-edge. For this purpose, the Contractor shall furnish and use an accurate 300-cm straight-edge swung from handles 100 cm (3 feet) longer than one-half the width of the slab. The straight-edge shall be held in contact with the surface in successive positions parallel to the road center line and the whole area gone over from one side of the slab to the other as necessary. Advances along the road shall be in successive stages of not more than one-half the length of the straight-edge. Any depressions found shall be immediately filled with freshly mixed concrete, struck off, consolidated and refinished. High areas shall be cut down and refinished. Special attention shall be given to assure that the surface across joints meets the requirements for smoothness. Straight-edge testing and surface corrections shall continue until the entire surface is found to be free from observable departures from the straight-edge and the slab conforms to the required grade and cross-section.

#### 7. Final Finish

If the surface texture is broom finished, it shall applied when the water sheen has practically disappeared. The broom shall be drawn from the center to the edge of the pavement with adjacent strokes slightly overlapping. The brooming operation should be so executed that the corrugations produced in the surface shall be uniform in appearance and not more than 1.5 mm in depth. Brooming shall be completed before the concrete is in such condition that the surface will be unduly roughened by the operation. The surface thus finished shall be free from rough and porous areas, irregularities, and depressions resulting from improper handling of the broom. Brooms shall be of the quality size and construction and be operated so as to produce a surface finish meeting the approval of the Engineer. Subject to satisfactory results being obtained and approval of the Engineer, the Contractor will be permitted to substitute mechanical brooming in lieu of the manual brooming herein described.

If the surface texture is belt finished, when straight-edging is complete and water sheen has practically disappeared and just before the concrete becomes non-plastic, the surface shall be belted with 2-ply canvass belt not less than 20 cm wide and at least 100 cm longer than the pavement width. Hand belts shall have suitable handles to permit controlled, uniform manipulation. The belt shall be operated with short strokes transverse to the center line and with a rapid advances parallel to the center line.

If the surface texture is drag finished, a drag shall be used which consists of a seamless strip of damp burlap or cotton fabric, which shall produce a uniform of gritty texture after dragging it longitudinally along the full width of pavement. For pavement 5 m or more in width, the drag shall be mounted on a bridge which travels on the forms. The dimensions of the drag shall be such that a strip of burlap or fabric at least 100 cm wide is in contact with the full width of pavement surface while the drag is used. The drag shall consist of not less than 2 layers of burlap with the bottom layer approximately 15 cm wider than the layer. The drag shall

be maintained in such condition that the resultant surface is of uniform appearance and reasonably free from grooves over 1.5 mm in depth. Drag shall be maintained clean and free from encrusted mortar. Drags that cannot be cleaned shall be discarded and new drags be substituted.

Regardless of the method used for final finish, the hardened surface of pavement shall have a coefficient of friction of 0.25 or more. Completed pavement that is found to have a coefficient of friction less than 0.25 shall be grounded or scored by the Contractor at his expense to provide the required coefficient of friction.

#### 8. Edging at Forms and Joints

After the final finish, but before the concrete has taken its initial set, the edges of the pavement along each side of each slab, and on each side of transverse expansion joints, formed joints, transverse construction joints, and emergency construction joints, shall be worked with an approved tool and rounded to the radius required by the Plans. A well – defined and continuous radius shall be produced and a smooth, dense mortar finish obtained. The surface of the slab shall not be unduly disturbed by tilting the tool during the use.

At all joints, any tool marks appearing on the slab adjacent to the joints shall be eliminated by brooming the surface. In doing this, the rounding of the corner of the slab shall not be disturbed. All concrete on top of the joint filler shall be completely removed.

All joints shall be tested with a straight-edge before the concrete has set and correction made if one edge of the joint is higher than the other.

#### **311.3.14 Surface Test**

As soon as the concrete has hardened sufficiently, the pavement surface shall be tested with a 3-m straight-edge or other specified device. Areas showing high spots of more than 3 mm but not exceeding 12 mm in 3 m shall be marked and immediately ground down with an approved grinding tool to an elevation where the area or spot will not show surface deviations in excess of 3 mm when tested with 3 m straight-edge. Where the departure from correct cross-section exceeds 12 mm, the pavement shall be removed and replaced by and at the expense of the Contractor.

Any area or section so removed shall be not less than 1.5 m in length and not less than the full width of the lane involved. When it is necessary to remove and replace a section of pavement, any remaining portion of the slab adjacent to the joints that is less than 1.5 m in length, shall also be removed and replaced.

#### **311.3.15 Curing**

Immediately after the finishing operations have been completed and the concrete has sufficiently set, the entire surface of the newly placed concrete shall be cured in accordance with either one of the methods described herein. Failure to provide sufficient cover material of whatever kind the Contractor may elect to use, or the lack of water to adequately take care of both curing and other requirements, shall be a cause for immediate suspension of concreting



operations. The concrete shall not be left exposed for more than ½ hour between stages of curing or during the curing period.

In all congested places, concrete works should be designed so that the designed strength is attained.

#### 1. Cotton of Burlap Mats

The surface of the pavement shall be entirely covered with mats. The mats used shall be of such length (or width) that as laid they will extend at least twice the thickness of the pavement beyond the edges of the slab. The mat shall be placed so that the entire surface and the edges of the slab are completely covered. Prior to being placed, the mats shall be saturated thoroughly with water. The mat shall be so placed and weighted down so as to cause them to remain in intimate contact with the covered surface. The mat shall be maintained fully wetted and in position for 72 hours after the concrete has been placed unless otherwise specified.

#### 2. Waterproof Paper

The top surface and sides of the pavement shall be entirely covered with waterproof paper, the units shall be lapped at least 45 cm. The paper shall be so placed and weighted down so as to cause it to remain in intimate contact with the surface covered. The paper shall have such dimension but each unit as laid will extend beyond the edges of the slab at least twice the thickness of the pavement, or at pavement width and 60 cm strips of paper for the edges. If laid longitudinally, paper not manufactured in sizes which will provide this width shall be securely sewed or cemented together, the joints being securely sealed in such a manner that they do not open up or separate during the curing period. Unless otherwise specified, the covering shall be maintained in place for 72 hours after the concrete has been placed. The surface of the pavement shall be thoroughly wetted prior to the placing of the paper.

#### 3. Straw Curing

When this type of curing is used, the pavement shall be cured initially with burlap or cotton mats, until after final set of the concrete or, in any case, for 12 hours after placing the concrete. As soon as the mats are removed, the surface and sides of the pavement shall be thoroughly wetted and covered with at least 20 cm of straw or hay, thickness of which is to be measured after wetting. If the straw or hay covering becomes displaced during the curing period, it shall be replaced to the original depth and saturated. It shall be kept thoroughly saturated with water for 72 hours and thoroughly wetted down during the morning of the fourth day, and the cover shall remain in place until the concrete has attained the required strength.

#### 4. Impervious Membrane Method

The entire surface of the pavement shall be sprayed uniformly with white pigmented curing compound immediately after the finishing of the surface and before the set of the concrete has taken place, or if the pavement is cured initially with jute or cotton mats, it may be applied upon removal of the mass. The curing compound shall not be applied during rain.

Curing compound shall be applied under pressure at the rate 4 L to not more than 14 m<sup>2</sup> by mechanical sprayers. The spraying equipment shall be equipped with a wind guard. At the

time of use, the compound shall be in a thoroughly mixed condition with the pigment uniformly dispersed throughout the vehicle. During application, the compound shall be stirred continuously by effective mechanical means. Hand spraying of odd widths or shapes and concrete surface exposed by the removal of forms will be permitted. Curing compound shall not be applied to the inside faces of joints to be sealed, but approved means shall be used to insure proper curing at least 72 hours and to prevent the intrusion of foreign material into the joint before sealing has been completed. The curing compound shall be of such character that the film will harden within 30 minutes after application. Should the film be damaged from any cause within the 72 hour curing period, the damaged portions shall be repaired immediately with additional compound.

## 5. White Polyethylene Sheet

The top surface and sides of the pavement shall be entirely covered with polyethylene sheeting. The units used shall be lapped at least 45 cm. The sheeting shall be so placed and weighted down so as to cause it to remain intimate contact with the surface covered. The sheeting as prepared for use shall have such dimension that each unit as laid will extend beyond the edges of the slab at least twice the thickness of the pavement. Unless otherwise specified, the covering shall be maintained in place for 72 hours after the concrete has been placed.

### **311.3.16 Removal of Forms**

After forms for concrete shall remain in place undisturbed for not less than twenty four (24) hours after concrete pouring. In the removal of forms, crowbars should be used in pulling out nails and pins. Care should be taken so as not to break the edges of the pavement. In case portions of the concrete are spalled, they shall be immediately repaired with fresh mortar mixed in the proportion of one part of Portland Cement and two parts fine aggregates. Major honeycomb areas will be considered as defective work and shall be removed and replaced at the expense of the Contractor. Any area or section so removed shall not be less than the distance between weakened plane joint nor less than the full width of the lane involved.

### **311.3.17 Sealing Joints**

Joints shall be sealed with asphalt sealant soon after completion of the curing period and before the pavement is opened to traffic, including the Contractor's equipment. Just prior to sealing, each joint shall be thoroughly cleaned of all foreign materials including membrane curing compound and the joint faces shall be clean and surface dry when the seal is applied.

The sealing material shall be applied to each joint opening to conform to the details shown on the Plans or as directed by the Engineer. Material for seal applied hot shall be stirred during heating so that localized overheating does not occur. The pouring shall be done in such a manner that the material will not be spilled on the exposed surfaces of the concrete. The use of sand or similar material as a cover for the seal will not be permitted.

Preformed elastomeric gaskets for sealing joints shall be of the cross-sectional dimensions shown on the Plans. Seals shall be installed by suitable tools, without elongation and secured in place with an approved lubricant adhesive which shall cover both sides of the concrete joints. The seals shall be installed in a compressive condition and shall at time of placement be below the level of the pavement surface by approximately 6 mm.

The seals shall be in one piece for the full width of each transverse joint.

### **311.3.18 Protection of Pavement**

The Contractor shall protect the pavement and its appurtenances against both public traffic and traffic caused by his own employees and agents. This shall include watchmen to direct traffic and the erection of and maintenance of warning signs, lights, pavement bridges or cross-overs, etc. The Plans or Special Provisions will indicate the location and type of device or facility required to protect the work and provide adequately for traffic.

All boreholes after thickness and/or strength determinations of newly constructed asphalt and concrete pavements shall be immediately filled/restored with the prescribed concrete/asphalt mix after completion of the drilling works.

Any damage to the pavement, occurring prior to final acceptance, shall be repaired or the pavement be replaced.

### **311.3.19 Concrete Pavement – Slip Form Method**

If the Contract calls for the construction of pavement without the use of fixed forms, the following provisions shall apply:

#### **1. Grade**

After the grade or base has been placed and compacted to the required density, the areas which will support the paving machine shall be cut to the proper elevation by means of a properly designed machine. The grade on which the pavement is to be constructed shall then be brought to the proper profile by means of properly designed machine. If the density of the base is disturbed by the grading operation, it shall be corrected by additional compaction before concrete is placed. The grade should be constructed sufficiently in advance of the placing of the concrete. If any traffic is allowed to use the prepared grade, the grade shall be checked and corrected immediately before the placing of concrete.

#### **2. Placing Concrete**

The concrete shall be placed with an approved slip-form paver designed to spread, consolidate, screed and float-finish the freshly placed concrete in one complete pass of the machine in such a manner that a minimum of hand finish will be necessary to provide a dense and homogenous pavement in conformance with the Plans and Specifications. The machine shall vibrate the concrete for the full width and depth of the strip of pavement being placed. Such vibration shall be accompanied with vibrating tubes or arms working in the concrete or with a vibrating screed or pan operating on the surface of the concrete. The sliding forms shall be rigidly held together laterally to prevent spreading of the forms. The forms shall trail behind the paver for such a distance that no appreciable slumping of the concrete will occur, and that necessary final finishing can be accomplished while the concrete is still within the forms. Any edge slump of the pavement, exclusive of edge rounding, in excess of 6 mm shall be corrected before the concrete has hardened.

The concrete shall be held at a uniform consistency, having a slump of not more than 40 mm (1-12/ inches). The slip form paver shall be operated with as nearly as possible a continuous forward movement and that all operations of mixing, delivering and spreading concrete shall be coordinated so as to provide uniform progress with stopping and starting of the paver held to a minimum. If, for any reason, it is necessary to stop the forward movement of the paver the vibratory and tamping elements shall also be stopped immediately. No tractive force shall be applied to the machine, except that which is controlled from the machine.

### 3. Finishing

The surface smoothness and texture shall meet the requirements of Subsections 311.3.13 and 311.3.14.

### 4. Curing

Unless otherwise specified, curing shall be done in accordance with one of the methods included in Subsection 311.3.15. The curing media shall be applied at the appropriate time and shall be applied uniformly and completely to all surfaces and edges of the pavement.

### 5. Joints

All joints shall be constructed in accordance with Subsection 311.3.12.

### 6. Protection Against Rain

In order that the concrete may be properly protected against rain before the concrete is sufficiently hardened, the Contractor will be required to have available at all times, materials for the protection of the edges and surface of the unhardened concrete. Such protective materials shall consist of standard metal forms or wood planks having a nominal thickness of not less than 50 mm (2 inches) and a nominal width of not less than the thickness of the pavement at its edge for the protection of the pavement edges, and covering material such as burlap or cotton mats, curing paper or plastic sheeting materials for the protection of the surface of the pavement. When rain appears imminent, all paving operations shall stop and all available personnel shall begin placing forms against the sides of the pavement and covering the surface of the unhardened concrete with the protective covering.

### **311.3.22 Acceptance of Concrete**

The strength level of the concrete will be considered satisfactory if the averages of all sets of three (3) consecutive strength test results equal or exceed the specified strength,  $f_c'$  and no individual strength test result is deficient by more than 15% of the specified strength,  $f_c'$ .

Concrete deemed to be not acceptable using the above criteria may be rejected unless the Contractor can provide evidence, by means of core tests, that the quality of concrete represented by failed test results is acceptable in place. At least three (3) representative cores shall be taken from each member or area of concrete in place that is considered deficient. The location of cores shall be determined by the Engineer so that there will be at least impairment of strength

of the structure. The obtaining and testing of drilled cores shall be in accordance with AASHTO T 24.

Concrete in the area represented by the cores will be considered adequate if the average strength of the cores is equal to at least 85% of, and if no single core is less than 75% of, the specified strength,  $f_c'$ .

If the strength of control specimens does not meet the requirements of this Subsection, and it is not feasible or not advisable to obtain cores from the structure due to structural considerations, payment of the concrete will be made at an adjusted price due to strength deficiency of concrete specimens as specified hereunder:

Deficiency in Strength of Concrete Specimens, Percent (%)	Percent (%) of Contract Price Allowed
Less than 5	100
5 to less than 10	80
10 to less than 15	70
15 to less than 20	60
20 to less than 25	50
25 or more	0

### 311.3.23 Opening to Traffic

The Engineer will decide when the pavement may be opened to traffic. The road will not be opened to traffic until test specimens molded and cured in accordance with AASHTO T 23 have attained the minimum strength requirements in Subsection 311.2.11. If such tests are not conducted prior to the specified age the pavement shall not be operated to traffic until 14 days after the concrete was placed. Before opening to traffic, the pavement shall be cleaned and joint sealing completed.

### 311.3.24 Tolerance and Pavement thickness

#### 1. General

The thickness of the pavement will be determined by measurement of cores from the completed pavement in accordance with AASHTO T 148.

The completed pavement shall be accepted on a lot basis. A lot shall be considered as 1000 linear meters of pavement when a single traffic lane is poured or 500 linear meters when two lanes are poured concurrently. The last unit in each slab constitutes a lot in itself when its length is at least ½ of the normal lot length. If the length of the last unit is shorter than ½ of the normal lot length, it shall be included in the previous lot.

Other areas such as intersections, entrances, crossovers, ramp, etc., will be grouped together to form a lot. Small irregular areas may be included with other unit areas to form a lot.

Each lot will be divided into five (5) equal segments and one core will be obtained from each segment in accordance with AASHTO T 24.

## 2. Pavement Thickness

It is the intent of this Specification that the pavement has a uniform thickness as called for on the Plans for the average of each lot as defined. After the pavement has met all surface smoothness requirements, cores for thickness measurements will be taken.

In calculating the average thickness of the pavement, individual measurements which are in excess of the specified thickness by more than 5 mm will be considered as the specified thickness plus 5 mm and measurement which are less than the specified thickness by more than 25 mm shall not be included in the average. When the average thickness for the lot is deficient, the contract unit price will be adjusted for thickness in accordance with paragraph (3 below).

Individual areas within a segment found deficient in thickness by more than 25 mm shall be evaluated by the Engineer, and if in his judgment, the deficient areas warrant removal, they shall be removed and replaced by the Contractor with pavement of the specified thickness at his entire expense. However, if the evaluation of the Engineer is that the deficient area should not be removed and replaced, such area will not be paid.

When the measurement of any core is less than the specified thickness by more than 25 mm, the actual thickness of the pavement in this area will be determined by taking additional cores at no less than 5 m intervals parallel to the center line in each direction from the affected location until a core is found in each direction, which is not deficient in thickness by more than 25 mm. The area of slab for which no payment will be made shall be the product of the paving width multiplied by the distance along the center line of the road between transverse sections found not deficient in thickness by more than 25 mm. The thickness of the remainder of the segment to be used to get the average thickness of each lot shall be determined by taking the average thickness of additional cores which are not deficient by more than 25 mm.

## 3. Adjustment for Thickness

When the average thickness of the pavement per lot is deficient, payment for the lot shall be adjusted as follows:

Deficiency in the Average Thickness per lot (mm)	Percent (%) of Contract Price Per Lot
0 – 5	100% payment
6 – 10	95% payment
11 – 15	85% payment
16 – 20	70% payment
21 – 25	50% payment
More than 25	Remove and replace/ No payment

No acceptance and final payment shall be made on completed pavement unless core test for thickness determination is conducted, except for Barangay Roads where the implementing office is allowed to waive such test.

### 311.4 Method of Measurement

The area to be paid for under this Item shall be the number of square meters (m<sup>2</sup>) of concrete pavement placed and accepted in the completed pavement. The width for measurements will be the width from outside edge to outside edge of completed pavement as placed in accordance with the Plans or as otherwise required by the Engineer in writing. The length will be measured horizontally along the center line of each roadway or ramp. Any curb and gutter placed shall not be included in the area of concrete pavement measured.

### 311.5 Basis of Payment

The accepted quantity, measured as prescribed in Section 311.4, shall be paid for at the contract unit price for Portland Cement Concrete Pavement, which price and payment shall be full compensation for preparation of roadbed and finishing of shoulders, unless otherwise provided by the Special Provisions, furnishing all materials, for mixing, placing, finishing and curing all concrete, for furnishing and placing all joint materials, for sawing weakened plane joints, for fitting the prefabricated center metal joint, for facilitating and controlling traffic, and for furnishing all labor, equipment, tools and incidentals necessary to complete the Item.

Payment will be made under:

Pay Item Number	Description	Unit of Measurement
311 (1)	PCC Pavement (Plain)	Square meter
311 (2)	PCC Pavement (Reinforced)	Square meter

## ITEM 403 – METAL STRUCTURES

### 403.1 Description

This work shall consist of steel structures and the steel structure portions of composite structures, constructed in reasonably close conformity with the lines, grades and dimensions shown on the Plans or established by the Engineer.

The work will include the furnishing, fabricating, hauling, erecting, welding and painting of structural metals called for in the Special Provision or shown on the Plans. Structural metals will include structural steel, rivet, welding, special and alloy steels, steel forgings and castings and iron castings. This work will also include any incidental metal construction not otherwise provided for, all in accordance with these Specifications, Plans and Special Provisions.

### 403.2 Material Requirements

Materials shall meet the requirements of Item 712, Structural Metal; Item 409, Welded Structural Steel, and Item 409, Welded Structural Steel; and Item 709, Paints.

### 403.3 Construction Requirements

#### 403.3.1 Inspection

The Contractor shall give the Engineer at least fifteen (15) days notice prior to the beginning of work at the mill or shop, so that the required inspection may be made. The term "mill" means any rolling mill, shop or foundry where material for the work is to be manufactured or fabricated. No material shall be rolled or fabricated until said inspection has been provided.

The Contractor shall furnish the Engineer with copies of the certified mill reports of the structural steel, preferably before but not later than the delivery of the steel to the job site.

The Contractor shall furnish all facilities for inspection and the Engineer shall be allowed free access to the mill or shop and premises at all times. The Contractor shall furnish, without charge, all labor, machinery, material and tools necessary to prepare test specimens.

Inspection at the mill or shop is intended as a means of facilitating the work and avoiding errors and it is expressly understood that it will not relieve the Contractor from any responsibility for imperfect material or workmanship and the necessity for replacing same. The acceptance of any material or finished member at the mill or shop by the Engineer shall not preclude their subsequent rejection if found defective before final acceptance of the work. Inspection of welding will be in accordance with the provision of Section 5 of the "Standard Code for Arc and Gas Welding in Building Construction" of the American Welding Society.

#### **403.3.2 Stock Material Control**

When so specified in the Contract, stock material shall be segregated into classes designated as "identified" or "unidentified". Identified material is material which can be positively identified as having been rolled from a given heat for which certified mill test can be produced. Unidentified material shall include all other general stock materials. When it is proposed to use unidentified material, the Engineer shall be notified of such intention at least fifteen (15) days in advance of commencing fabrication to permit sampling and testing. When so indicated or directed, the Contractor shall select such material as he wishes to use from stock, and place it in such position that it will be accessible for inspection and sampling. The Contractor shall select identified material from as few heat numbers as possible, and furnish the certified mill test reports on each of such heat numbers. Two samples shall be taken from each heat number as directed, one for a tension test and one for a bend test.

In the case of unidentified stock, the Engineer may, at his discretion, select any number of random test specimens.

Each bin from which rivets or bolts are taken shall subject to random test. Five rivets or bolts may be selected by the Engineer from each bin for test purposes.

Structural material, either plain or fabricated, shall be stored above the ground upon platforms, skids, or other supports. It shall be kept free from dirt, grease, or other foreign matter, and shall be protected as far as practicable from corrosion.

#### **403.3.3 Fabrication**



These Specifications apply to riveted, bolted and welded construction. The Contractor may, however, with approval of the Engineer, substitute high tensile strength steel bolts equivalent to the rivets in any connection.

Workmanship and finish shall be in accordance with the best general practice in modern bridge shops. Portions of the work exposed to view shall be finished neatly. Shearing, flame cutting, and chipping shall be done carefully and accurately.

Structural material, either plain or fabricated, shall be stored above the ground upon platforms, skids or other supports. It shall be kept free from dirt, grease or other foreign matter, and shall be protected as far as practicable from corrosion.

Rolled material before being laid off or worked must be straight. If straightening is necessary, it shall be done by methods that will not injure the metal. Sharp kinks and bends will be cause for rejection of the material.

Preparation of material shall be in accordance with AWS (American Welding Society) D 1.1, paragraph 3.2 as modified by AASHTO Standard Specification for Welding of Structural Steel Highway Bridges.

**403.3.4 Finishing and Shaping**

Finished members shall be true to line and free from twists, bends and open joints.

1. Edge Planing

Sheared edges of plates more than 15.9 mm in thickness and carrying calculated stresses shall be planed to a depth of 6.3 mm. Re-entrant cuts shall be filleted before cutting.

2. Facing of Bearing Surfaces

The surface finish of bearing and based plates and other bearing surfaces that are to come in contact with each other or with concrete shall meet the American National Standards Institute surface roughness requirements as defined in ANSI B-46.1-47, Surface Roughness Waviness and Lay, Part I:

Steel slabs	ANSI 2,000
Heavy plates in contact in shoes to Be welded	ANSI 1,000
Milled ends of compression members, stiffeners and fillers	ANSI 500
Bridge rollers and rockers	ANSI 250
Pins and pin holes	ANSI 125
Sliding bearings	ANSI 125

3. Abutting Joints

Abutting joints in compression members and girders flanges, and in tension members where so specified on the drawings, shall be faced and brought to an even bearing. Where joints are not faced, the opening shall not exceed 6.3 mm.

#### 4. End Connection Angles

Floor beams, stringers and girders having end connection angles shall be built to plan length back to back of connection angles with a permissible tolerance of 0 mm to minus 1.6 mm. If end connections are faced, the finished thickness of the angles shall not be less than that shown on the detail drawings, but in no case less than 9.5 mm.

#### 5. Lacing Bars

The ends of lacing bars shall be neatly rounded unless another form is required.

#### 6. Fabrication of Members

Unless otherwise shown on the Plans, steel plates for main members and splice plates for flanges and main tension members, not secondary members, shall be cut and fabricated so that the primary direction of rolling is parallel to the direction of the main tensile and/or compressive stresses.

Fabricated members shall be true to line and free from twists, bends and open joints.

#### 7. Web Plates (Riveted or Bolted)

In girders having no cover plates and not to be encased in concrete, the top edges of the web shall not extend above the backs of the flange angles and shall not be more than 3.2 mm below at any point. Any portion of the plate projection beyond the angles shall be chipped flush with the backs of the angles. Web plates of girders having cover plates may not be more than 12.7 mm less in width than the distance back to back of flange angles.

Splices in webs of girders without cover plates shall be sealed on top with red lead paste prior to painting.

At web splices, the clearance between the ends of the plates shall not exceed 9.5 mm. The clearance at the top and bottom ends of the web splice plates shall not exceed 6.3 mm.

#### 8. Bent Plates

Cold-bent load-carrying rolled-steel plates shall conform to the following:

a. They shall be so taken from the stock plates that the bendline will be at right angles to the direction of rolling, except that cold-bent ribs for orthotropic deck bridges may be bent in the direction of rolling if permitted by the Engineer.

b. The radius of bends shall be such that no cracking of the plate occurs. Minimum bend radii, measured to the concave face of the metal, are shown in the following table:

ASTM DESIG- ATION	THICKNESS, t in mm					
	Up to 6.3	Over 6.3 To 12.7	Over 12.7 To 25.4	Over 25.4 to 38.1	Over 38.1 to 50.08	
A36	1.5t	1.5t	2t	3t	4t	
A242	2t	3t	5t	a---	a---	
A440	2.5t	3.5t	6t	a---	a---	
A441	2t	3t	5t	a---	a---	
A529	2t	2t	----	----	----	
A572	Gr.42	2t	2t	3t	4t	5t
	Gr.45	2t	2t	3t	4t	----
	Gr.50	2.5t	2.5t	4t	a---	----
	Gr.55	3t	3t	5t	a---	----
	Gr.60	3.5t	3.5t	6t	----	----
	Gr.65	4t	4t	----	----	----
A588	2t	3t	5t	a---	a---	
A514 <sup>b</sup>	2t	2t	2t	3t	3t	

<sup>a</sup> It is recommended that steel in this thickness range be bent hot. Hot bending however, may result in a slight decrease in the as-rolled mechanical properties.

<sup>b</sup> The mechanical properties of ASTM A 514 steel results from a quench-and-temper-operation. Hot bending may adversely affect these mechanical properties. If necessary to hotbend, fabricator should discuss procedure with steel supplier.

c. Before bending, the corners of the plate be rounded to a radius of 1.6 mm throughout that portion of the plate where the bending is to occur.

## 9. Fit of Stiffeners

End stiffeners of girders and stiffeners intended as supports for concentrated loads shall have full bearing (either milled, ground or on weldable steel in compression areas of flanges, welded as shown on the Plans or specified) on the flanges to which they transmit load or from which they receive load. Stiffeners not intended to support concentrated loads shall, unless shown or specified otherwise, fit sufficiently tight to exclude water after being painted, except that for welded flexural members, the ends of stiffeners adjacent to the tension flanges shall be cut back as shown on the Plans. Fillers under stiffeners shall fit within 6.3 mm at each end.

Welding will be permitted in lieu of milling or grinding if noted on the Plans or in the Special Provisions. Brackets, clips, gussets, stiffeners, and other detail material shall not be welded to members or parts subjected to tensile stress unless approved by the Engineer.

## 10. Eyebars

Pin holes may be flame cut at least 50.8 mm smaller in diameter than the finished pin diameter. All eyebars that are to be placed side by side in the structure shall be securely fastened together in the order that they will be placed on the pin and bored at both ends while

so clamped. Eyebars shall be packed and matchmarked for shipment and erection. All identifying marks shall be stamped with steel stencils on the edge of one head of each member after fabrication is completed so as to be visible when the bars are nested in place on the structure. The eyebars shall be straight and free from twists and the pin holes shall be accurately located on the centerline of the bar. The inclination of any bar to the plane of the truss shall not exceed 1.6 mm to 305 mm.

The edges of eyebars that lie between the transverse centerline of their pin holes shall be cut simultaneously with two mechanically operated torches abreast of each other, guided by a substantial template, in such a manner as to prevent distortion of the plates.

#### 11. Annealing and Stress Relieving

Structural members which are indicated in the Contract to be annealed or normalized shall have finished machining, boring and straightening done subsequent to heat treatment. Normalizing and annealing (full annealing) shall be in accordance with ASTM E 44. The temperatures shall be maintained uniformly throughout the furnace during heating and cooling so that the temperature at no two points on the member will differ by more than 37.8<sup>0</sup>C at any one time.

Members of A514/A517 steels shall not be annealed or normalized and shall be stress relieved only with the approval of the Engineer.

A record of each furnace charge shall identify the pieces in the charge and show the temperatures and schedule actually used. Proper instruments including recording pyrometers, shall be provided for determining at any time the temperatures of members in the furnace. The records of the treatment operation shall be available to and meet the approval of the Engineer.

Members, such as bridge shoes, pedestals, or others which are built up by welding sections of plate together shall be stress relieved in accordance with the provisions of Subsection 403.3.11 when required by the Plans, Specifications or Special Provisions governing the Contract.

#### 12. Tests

When full size tests of fabricated structural members or eyebars are required by the Contract, the Plans or Specifications will state the number and nature of the tests, the results to be attained and the measurements of strength, deformation or other performances that are to be made. The Contractor will provide suitable facilities, material, supervision and labor necessary for making and recording the tests. The members tested in accordance with the Contract will be paid for in accordance with Subsection 403.3.5.1. The cost of testing, including equipment handling, supervision labor and incidentals for making the test shall be included in the contract price for the fabrication or fabrication and erection of structural steel, whichever is the applicable item in the Contract, unless otherwise specified.

#### **403.3.5 Pins and Rollers**

Pins and rollers shall be accurately turned to the dimensions shown on the Plans and shall be straight, smooth, and free from flaws. Pins and rollers more 228.6 mm or less in diameter may

either be forged and annealed. Pins and rollers 228.6 mm or less in diameter may either be forged and annealed or cold-finished carbon-steel shafting.

In pins larger than 228.6 mm in diameter, a hole not less than 50.8 mm in diameter shall be bored full length along the axis after the forging has been allowed to cool to a temperature below the critical range under suitable conditions to prevent injury by too rapid cooling and before being annealed.

Pin holes shall be bored true to the specified diameter, smooth and straight, at right angles with the axis of the member and parallel with each other unless otherwise specified. The final surface shall be produced by a finishing cut.

The distance outside to outside of holes in tension members and inside to inside of holes in compression members shall not vary from that specified more than 0.8 mm. Boring of holes in built-up members shall be done after the riveting is completed.

The diameter of the pin hole shall not exceed that of the pin by more than 0.51 mm for pins 127 mm or less in diameter, or 0.8 mm for larger pins.

The pilot and two driving nuts for each size of pin shall be furnished, unless otherwise specified.

#### **403.3.6 Fastener Holes (Rivets and Bolts)**

All holes for rivets or bolts shall be either punched or drilled. Material forming parts or a member composed of not more than five thickness of metal may be punched 1.6 mm larger than the nominal diameter of the rivets or bolts whenever the thickness of the material is not greater than 19 mm for structural steel, 15.9 mm for high-strength steel or 12.7 mm for quenched and tempered alloy steel, unless subpunching and reaming is required for field connections.

When there are more than five thicknesses or when any of the main material is thicker than 19 mm for structural steel, 15.9 mm for high-strength steel, or 12.7 mm for quenched and tempered alloy steel, all holes shall either be subdrilled or drilled full size.

When required for field connections, all holes shall either be subpunched or subdrilled (subdrilled if thickness limitation governs) 4.8 mm smaller and, after assembling, reamed 1.6 mm larger or drilled full size 1.6 mm larger than the nominal diameter of the rivets or bolts.

When permitted by design criteria, enlarged or slotted holes are allowed with high-strength bolts. For punched holes, the diameter of the die shall not exceed the diameter of the punch by more than 1.6 mm. If any holes must be enlarged to admit the fasteners, they shall be reamed. Holes shall be clean cut, without torn or ragged edges. Poor matching of holes will be cause for rejection.

Reamed holes shall be cylindrical, perpendicular to the member, and not more than 1.6 mm larger than the nominal diameter of the fasteners. Where practicable, reamers shall be directed by mechanical means. Drilled holes shall be 1.6 mm larger than the nominal diameter of the fasteners. Burrs on the outside surfaces shall be removed. Poor matching of holes will be

cause for rejection. Reaming and drilling shall be done with twist drills. If required by the Engineer, assembled parts shall be taken apart for removal of burrs caused by drilling. Connecting parts requiring reamed or drilled holes shall be assembled and securely held while being reamed or drilled and shall be matchmarked before disassembling.

Unless otherwise specified, holes for all field connections and field splices of main truss or arch members, continuous beams, towers (each face), bents, plate girders and rigid frames shall be subpunched (or subdrilled if subdrilling is required) and subsequently reamed while assembled in the shop in accordance with Subsection 403.3.7.

All holes for floor-beam and stringer field end connections shall be subpunched and reamed to a steel template reamed while being assembled.

Reaming or drilling full size of field connection through templates shall be done after templates have been located with the utmost care as to position and angle and firmly bolted in place. Templates used for the reaming of matching members, or of the opposite faces of one member, shall be exact duplicates. Templates for connections which duplicate shall be so accurately located that like members are duplicates and require no matchmarking.

If additional subpunching and reaming is required, it will be specified in the Special Provisions or on the Plans.

Alternately, for any field connection or splice designated above in lieu of sub-sized holes and reaming while assembled, or drilling holes full-size while assembled, the Contractor shall have the option to drill bolt holes full-size in unassembled pieces and/or connections including templates for use with matching sub-sized and reamed holes means of suitable numerically-controlled (N/C) drilling equipment subject to the specific provisions contained in this Subsection.

If N/C drilling equipment is used, the Engineer, unless otherwise stated in the Special Provisions or on the Plans, may require the Contractor, by means of check assemblies to demonstrate that this drilling procedure consistently produces holes and connections meeting the requirements of conventional procedures.

The Contractor shall submit to the Engineer for approval a detailed outline of the procedures that he proposes to follow in accomplishing the work from initial drilling through check assembly, if required, to include the specific members of the structure that may be N/C drilled, the sizes of the holes, the location of common index and other reference points, composition of check assemblies and all other pertinent information.

Holes drilled by N/C drilling equipment shall be drilled to appropriate size either through individual pieces, or any combination of pieces held tightly together.

All holes punched full size, subpunched or subdrilled shall be so accurately punched that after assembling (before any reaming is done), a cylindrical pin 3.2 mm smaller in diameter than the nominal size of the punched hole may be entered perpendicular to the face of the member, without drifting, in at least 75 percent of the contiguous holes in the same plane. If the requirement is not fulfilled, the badly punched pieces will be rejected. If any hole will not

pass a pin 4.8 mm smaller in diameter than the nominal size of the punched holes, this will cause for rejection.

When holes are reamed or drilled, 85 percent of the holes in any continuous group shall, after reaming or drilling, show no offset greater than 0.8 mm between adjacent thickness of metal.

All steel templates shall have hardened steel bushings in holes accurately dimensioned from the center lines if the connections as inscribed on the template. The center lines shall be used in locating accurately the template from the milled or scribed ends of the members.

#### **403.3.7 Shop Assembly**

##### **1. Fitting for Riveting and Bolting**

Surfaces of metal in contact shall be cleaned before assembling. The parts of a member shall be assembled, well pinned and firmly drawn together with bolts before reaming or riveting is commenced. Assembled pieces shall be taken apart, if necessary, for the removal of burrs and shavings produced by the reaming operation. The member shall be free from twists, bends and other deformation. Preparatory to the shop riveting of full-sized punched material, the rivet holes, if necessary, shall be spear-reamed for the admission of the rivets. The reamed holes shall not be more than 1.6 mm larger than the nominal diameter of the rivets.

End connection angles, and similar parts shall be carefully adjusted to correct positions and bolted, clamped, or otherwise firmly in place until riveted.

Parts not completely riveted in the shop shall be secured by bolts, in so far as practicable, to prevent damage in shipment and handling.

##### **2. Shop Assembling**

The field connections of main members of trusses, arches, continuous beam spans, bents, towers (each face), plate girders and rigid frames shall be assembled in the shop with milled ends of compression members in full bearing, and then shall have their sub-size holes reamed to specified size while the connections are assembled. Assembly shall be "Full Truss or Girders Assembly" unless "Progressive Chord Assembly" or "Special Complete Structure Assembly" is specified in the Special Provisions or on the Plans.

Check assemblies with Numerically-Controlled Drilled Fields Connections shall be in accordance with the provision of 2 (f) of this Subsection.

Each assembly, including camber, alignment, accuracy of holes and fit of milled joints, shall be approved by the Engineer before reaming is commenced or before an N/C drilled check assembly is dismantled.

The fabricator shall furnish the Engineer a camber diagram showing the camber at each panel point in the cases of trusses or arch ribs and at the location of field splices and fractions of span length (0.25 points minimum, 0.10 points maximum) in case of continuous beam and girders or rigid frames. When the shop assembly is Full Truss or Girder Assembly or Special Complete Structure Assembly, the camber diagram shall show the camber measured in

assembly. When any of the other methods of shop assembly is used, the camber diagram shall show calculated camber.

Methods of assembly shall be described below:

a. Full of Truss or Girders Assembly shall consist of assembling all members of each truss, arch rib, bent, tower face, continuous beam line, plate girder or rigid frame at one time.

b. Progressive Truss or Girder Assembly shall consist of assembling initially for each truss, arch rib, bent, tower face, continuous beam line, plate girder, or rigid frame all members in at least three continuous shop sections or panels but not less than the number of panels associated with three continuous chord lengths (i.e., length between field splices) and not less than 45.72 m in case of structures longer than 45.72 m. At least one shop section or panel or as many panels as are associated with a chord length shall be added at the advancing end of the assembly before any member is removed from the rearward end so that the assembled portion of the structure is never less than that specified above.

c. Full Chord Assembly shall consist of assembling with geometric angles at the joints, the full length of each chord or each truss or open spandrel arch, or each leg of each bent or tower, than reaming their field connection holes while the members are assembled; and reaming the web member connections to steel templates set at geometric (not cambered) angular relation to the chord lines. Field connection holes in web members shall be reamed to steel templates. At least one end of each web member shall be milled or shall be scribed normal to the longitudinal axis of the member and the templates of both ends of the member shall be accurately located from one of the milled ends or scribed line.

d. Progressive Chord Assembly shall consist of assembling contiguous chord members in the manner specified for Full Chord Assembly, and in the number and length specified for Progressive Truss or Girder Assembly.

e. Special Complete Structure Assembly shall consist of assembling the entire structure, including the floor system. (This procedure is ordinarily needed only for complicated structures such as those having curved girders, or extreme skew in combination with severe grade or camber). The assembly including camber, alignment, accuracy of holes and fit of milled joints shall be approved by the Engineer before reaming is commenced.

A Contractor shall furnish the Engineer a camber diagram showing the camber at each panel point of each truss, arch rib, continuous beam line, plate girder or rigid frame. When shop assembly is Full Truss or Girder Assembly or Special Complete Structure Assembly, the camber diagram shall show the camber measured in assembly. When any of the other methods of shop assembly is used, the camber diagram shall show calculated camber.

f. Check Assemblies with Numerically-Controlled Drilled Field Connections. A check assembly shall be required for each major structural type of each project, unless otherwise designated on the Plans or in the Special Provisions, and shall consist of at least three contiguous shop sections or, in a truss, all members in at least three contiguous panels but not less than the number of panels associated with three contiguous chord lengths (i.e., length between field splices). Check assemblies should be based on the proposed order



erection, joints in bearings, special complex points, and similar considerations. Such special points could be the portals of skewed trusses, etc.

Use of either geometric angles (giving theoretically zero secondary stresses under deadload conditions after erection) or cambered angles (giving theoretically zero secondary stresses under no-load conditions) should be designated on the Plans or in the Special Provisions.

The check assemblies shall be preferably be the first such sections of each major structural type to be fabricated.

No matchmaking and no shop assemblies other than the check assemblies shall be required.

If the check assembly fails in some specific manner to demonstrate that the required accuracy is being obtained, further check assemblies may be required by the Engineer for which there shall be no additional cost to the contracting authority.

#### **403.3.8 Rivets and Riveting**

The size of rivets called for on the Plans shall be the size before heating. Rivet heads shall be of standard shape, unless otherwise specified, and of uniform size for the same diameter of rivet. They shall be full, neatly made, concentric with the rivets holes, and in full contact with the surface of the member. Sufficient rivets for field connections shall be furnished to rivet the entire structure with an ample surplus to replace all rivets burned, lost or cut out.

Rivets shall be heated uniformly to a "light cherry red color" and shall be driven while hot. Any rivet whose point is heated more than the remainder shall not be driven. When a rivet is ready for driving, it shall be free from slag, scale and other adhering matter. Any rivet which is sealed excessively, will be rejected.

All rivets that are loose, burned, badly formed, or otherwise defective shall be removed and replaced with satisfactory rivets. Any rivet whose head is defective in size or whose head is driven off center will be considered defective and shall be removed. Stitch rivets that are loosened by driving of adjacent rivets shall be removed and replaced with satisfactory rivets. Caulking, recapping, or double gunning of rivets heads will not be permitted.

Shop rivets shall be driven by direct-acting rivet machines when practicable. Approved bevelled rivet sets shall be used for forming rivet heads on sloping surfaces. When the use of a direct-acting rivet machine is not practicable, pneumatic hammers of approved size shall be used. Pneumatic bucking tools will be required when the size and length of the rivets warrant their use.

Rivets may be driven cold provided their diameter is not over 9.5 mm.

#### **403.3.9 Bolted Connections, Unfurnished, Turned and Ribbed Bolts**

##### **1. General**

Bolts under this Subsection shall conform to “Specifications for Carbon Steel Externally and Internally Threaded Standard Fasteners”, ASTM A 307. Specifications for high strength bolts are covered under Subsection 403.3.10.

Bolts shall be unfinished, turned or an approved form of ribbed bolts with hexagonal nuts and heads except that ribbed bolts shall have button heads. Bolted connections shall be used only as indicated by the Plans or Special Provisions. Bolts not tightened to the proof loads shall have single self locking nuts or double nuts. Bevel washers shall be used where bearing faces have a slope or more than 1:20 with respect to a plane normal to the bolt axis. Bolts shall be of such length that will extend entirely through their nuts but not more than 6.3 mm beyond them.

Bolts shall be driven accurately into the holes without damage to the threads. A snap shall be used to prevent damage to the heads. The heads and nuts shall be drawn tight against the work with the full effort of a man using a suitable wrench, not less than 381 mm long for bolts of nominal diameter 19 mm and over. Heads of bolts shall be tapped with a hammer while the nuts are being tightened.

## 2. Unfinished Bolts

Unfinished bolts shall be furnished unless other types are specified. The number of bolts furnished shall be 5 percent more than the actual number shown on the Plans for each size and length.

## 3. Turned Bolts

The surface of the body of turned bolts shall meet the ANSI roughness rating value of 125. Heads and nuts shall be hexagonal with standard dimensions for bolts of the nominal size specified or the next larger nominal size. Diameter of threads shall be equal to the body of the bolt or the nominal diameter of the bolt specified. Holes for turned bolts shall be carefully reamed with bolts furnished to provide for a light driving fit. Threads shall be entirely outside of the holes. A washer shall be provided under the nut.

## 4. Ribbed Bolts

The body of ribbed shall be of an approved form with continuous longitudinal ribs. The diameter of the body measured on a circle through the points of the ribs shall be 1.98 mm greater than the nominal diameter specified for the bolts.

Ribbed bolts shall be furnished with round heads conforming to ANSI B 18.5 unless otherwise specified. Nuts shall be hexagonal, either recessed or with a washer of suitable thickness. Ribbed bolts shall make a driving fit with the holes. The hardness of the ribs shall be such that the ribs do not mash down enough to permit the bolts to turn in the holes during tightening. If for any reason the bolt twists before drawing tight, the holes shall be carefully reamed and an oversized bolt used as a replacement. The Contractor shall provide and supply himself with oversize bolts and nuts for this replacement in an amount not less than ten percent (10%) of the number of ribbed bolts specified.

### **403.3.10 Bolted Connections (High Tensile-Strength Bolts)**

1. Bolts

Bolts shall be AASHTO M 164 (ASTM A 325 or AASHTO M 253) tensioned to a high tension. Other fasteners which meet the chemical requirements of AASHTO M 164 or M 253 and which meet the mechanical requirements of the same specification in full size tests and which have body diameter and bearing areas under the head and nut, or their equivalents, not less than those provided by a bolt and nut of the same nominal dimensions prescribed above, may be used subject to the approval of the Engineer.

Bolts lengths shall be determined by adding the grip-length values given in Table 403.1 to the total thickness of connected material. The values of Table 403.1 compensate for manufacturer's tolerance, the use of heavy semi-finished hexagon nut and a positive "stick-through" at the end of the bolt. For each hardened flat washer that is used add 4 mm to the tabular value and for each bevelled washer add 7.9 mm. The length determined shall be adjusted to the next longer 6.3 mm.

**Table 403.1 – Grip-Length Values**

Bolts Size (mm)	To determine required bolt length, add grip (mm) *
9.5	17.5
12.7	22.2
19.0	25.4
22.2	28.6
25.4	31.7
28.6	38.1
31.7	41.3
34.9	44.4
38.1	47.6

\* Does not include allowance for washer thickness

2. Bolted Parts

The slope of surface of bolted parts in contact with the bolt head and nut shall not exceed 1:20 with respect to a plane normal to the bolt axis. Bolted parts shall fit solidly together when assembled and shall not be separated by gaskets or any other interposed compressible material. When assembled, all joint surfaces, including those adjacent to the bolt head, nuts or washers, shall be free of scale, except tight mill scale, and shall also be free of burrs, dirt and other foreign material that would prevent solid seating of the parts. Paint is permitted unconditionally in bearing-type connections.

In friction-type connections, the Class, as defined below, indicating the condition of the contact surfaces shall be specified on the Plans. Where no Class is specified, all joint surfaces shall be free of scale, except tight mill scale and shall not have a vinyl wash.

a. Classes A, B and C (uncoated). Contact surfaces shall be free of oil, paint, lacquer or other coatings.

b. Class D (hot-dip galvanized and roughened). Contact surfaces shall be tightly scored by wire brushing or blasting after galvanizing and prior to assembly. The wire brushing treatment shall be a light application of manual or power brushing that marks or scores the surface but remove relatively little of the zinc coating. The blasting treatment shall be a light “brush-off” treatment which will produce a dull gray appearance. However, neither treatment should be severed enough to produce any break or discontinuity in the zinc surface.

c. Classes E and F (blast-cleaned, zinc rich paint). Contact surfaces shall be coated with organic or inorganic zinc rich paint as defined in the Steel Structures Painting Council Specification SSPC 12.00.

d. Classes G and H (blast-cleaned, metallized zinc or aluminum). Contact surfaces shall be coated in accordance with AWS C2.2, Recommended Practice for Metallizing with Aluminum and Zinc for Protection of Iron and Steel, except that subsequent sealing treatments, described in Section IV therein shall not be used.

e. Class I (vinyl wash). Contact surfaces shall be coated in accordance with the provisions of the Steel Structure Painting Council Pretreatment Specifications SSPC PT3.

AASHTO M 164 (ASTM A 325) Type 2 and AASHTO M 253 bolts shall not be galvanized nor shall they be used to connect galvanized material.

### 3. Installation

a. Bolt Tension. Each fastener shall be tightened to provide, when all fasteners in the joints are tight at least the minimum bolt tension shown in Table 403.2 for the size of fastener used.

Threaded bolts shall be tightened with properly calibrated wrenches or by the turn-of-nut method. If required, because of bolt entering and wrench operation clearances, tightening by either procedure may be done by turning the bolt while the nut is prevented from rotating. Impact wrenches, if used, shall be of adequate capacity and sufficiently supplied with air to perform the required tightening of each bolt in approximately ten seconds.

AASHTO M 253 and galvanized AASHTO M 164 (ASTM A 325) bolts shall not be reused. Other AASHTO M 164 (ASTM A 325) bolts may be reused, but not more than once, if approved by the Engineer. Retightening previously tightened bolts which may have been loosened by the tightening of adjacent bolts shall not be considered as a reuse.

b. Washers. All fasteners shall have a hardened washer under the element (nut or bolt head) turned in tightening except that AASHTO M 164 (ASTM A 325) bolts installed by the turn of the nut method in holes which are not oversized or slotted may have the washer omitted. Hardened washers shall be used under both the head and nut regardless of the element turned in the case of AASHTO M 253 bolts if the material against which it bears has a specified yield strength less than 275.76 MPa.

### **Table 403.2 – Bolt Tension**

Bolt Size, mm	Minimum Bolt Tension <sup>1</sup> , kg.	
	AASHTO M 164 (ASTM A 325) Bolts	AASHTO M 253 (ASTM A 420) Bolts
12.7	5 466	6 758
15.9	8 709	10 569
19.0	12 882	15 821
22.2	13 268	21 999
25.4	23 360	24 312
28.6	25 605	36 786
31.7	32 522	45 858
34.9	38 760	55 111
38.1	47 174	66 905

<sup>1</sup> **Equals to 70 percent of specified minimum tensile strength bolts. Where an outer face of the bolted parts has a slope of more than 1:20 with respect to a Plane normal to the bolt axis, a smooth bevelled washer shall be used to compensate for the lack of parallel line.**

c. **Calibrated Wrench Tightening.** When Calibrated wrenches are used to provide the bolt tension as specified above, their setting shall be such as to induce a bolt tension 5 to 10 percent in excess of this value. These wrenches shall be calibrated at least once each working day by tightening, in a device capable of indicating actual bolt tension, not less than three typical bolts of each diameter from the bolts to be installed. Power wrenches shall be adjusted to installed or cut-out at the selected tension. If manual torque wrenches are used, the torque indication corresponding to the calibrating tension shall be noted and used in the installation of all the tested lot. Nuts shall be turned in the tightening direction when torque is measured. When using calibrated wrenches to install several bolts in a single joint, the wrench shall be returned to “touch-up” bolts previously tightened which may have been loosened by the tightening of adjacent bolts, until all are tightened to the prescribed amount.

d. **Turn-of-Nut Tightening.** When the turn-of-nut method is used to provide the bolt tension specified in (a) above, there shall first be enough bolts brought to a “snug tight” condition to insure that the parts of the joint are brought into full contact with each other. Snug tight is defined as the tightness attained by a few impacts of an impact wrench or the full effort of a man using an ordinary spud wrench. Following this initial operation, bolts shall be placed in any remaining holes in the connection and brought to snug tightness.

All bolts in the joints shall then be tightened additionally, by the applicable amount of nut rotation specified in Table 403.3 with tightening progressing systematically from the most rigid part of the joint to its free edges. During this operation, there shall be no rotation of the part not turned by the wrench.

e. **Lock Pin and Collar Fasteners.** The installation of lock pin and collar fasteners shall be by methods approved by the Engineer.

Table 403.3 – Nut Rotation From Snug Tight Condition<sup>‡</sup>

Bolt Length measured from underside of head to extreme end of point	Disposition of Outer Faces of Bolted Parts		
	Both faces normal to bolt axis	One face normal to bolt axis and other face sloped not more 1:20 (bevel washer not used)	Both faces sloped not more than 1:20 from normal to bolt axis (bevel washers not used)
Up to and including 4 diameters	0.33 turn	0.5 turn	0.66 turn
Over 4 diameters but not exceeding 8 diameters	0.5 turn	0.66 turn	0.625 turn
Over 8 diameters but not exceeding 12 diameters <sup>2</sup>	0.66 turn	0.83 turn	1 turn

<sup>1</sup> **Nut rotation is relative to bolt, regardless of the element (nut or bolt) being turned. For bolts installed by 1/2 turn and less the tolerance should be plus or minus 30<sup>0</sup>, for bolts installed by 2/3 turn and more, the tolerance should be plus or minus 45<sup>0</sup>.**

<sup>2</sup> **No research work has been performed by the Research Council on Riveted and Bolted Structural joints to establish the turn-of-nut procedure when bolt lengths exceed 12 diameters. Therefore, the required rotation must be determined by actual tests in a suitable tension device simulating the actual conditions.**

#### 4. Inspection

The Engineer will determine that the requirements of these Specifications are not in the work. When the calibrated wrench method of tightening is used, the Engineer shall have full opportunity to witness the calibration tests.

The Engineer will observe the installation and tightening of the bolts to determine that the selected tightening procedure is properly used and will determine that all bolts are tightened.

The following inspection shall be used unless a more extensive or different procedure is specified:

a. The Contractor shall use an inspecting wrench which may either be a torque wrench or a power wrench that can be accurately adjusted in accordance with the requirements of Subsection 403.3.10(3) (c) above, in the presence of the Engineer.

b. Three bolts of the same grade, size and condition as those under inspection shall be placed individually in a calibration device capable of indicating bolt tension. Length may be

any length representative of bolts used in the structure. There shall be a washer under the part turned in tightening each bolt.

c. When the inspecting wrench is a torque wrench, each of the three bolts specified above shall be tightened in the calibration device by any convenient means to the minimum tension specified for its size in Table 403.2. The inspecting wrench shall then be applied to the tightened bolt and the torque necessary to run the nut or head 5 degrees (approximately 25.4 mm at 304.8 mm radius) in the tightening direction shall be determined. The average torque measured in the tests of three bolts shall be taken as the job inspection torque to be used in the manner specified below.

d. When the inspecting wrench is a power wrench, it shall be adjusted so that it will tighten each of the three bolts specified to a tension at least 5 but not more than 10 percent greater than the minimum tension specified for its size in Table 403.2. This setting of wrench shall be taken as the job inspecting torque to be used in the manner specified below.

e. Bolts, represented by the three samples bolts prescribed above, which have been tightening in the structure shall be inspected by applying, in the tightening direction, the inspecting wrench and its job inspecting torque to 10 percent of the bolts, but not less than two bolts selected at random in each connection. If no nut or bolt head is turned by this application of the job inspecting torque, the connection shall be accepted as properly tightened. If any nut or bolt head is turned by the application of the job inspecting torque, this torque shall be applied to all bolts in the connection, and all bolts whose nut or head is turned by the job inspecting torque shall be tightened and re-inspected, or alternatively, the fabricator or erector, at his option may re-tighten all the bolts in the connection and then resubmit the connection for the specified inspection.

#### **403.3.11 Welding**

Welding shall be done in accordance with the best modern practice and the applicable requirements at AWS D1.1 except as modified by AASHTO “Standard Specifications for Welding of Structural Steel Highway Bridges”.

#### **403.3.12 Erection**

##### **1. General**

The Contractor shall provide the falsework and all tools, machinery and appliances, including driftpins and fitting-up bolts, necessary for the expeditious handling of the work and shall erect the metal work, remove the temporary construction, and do all work necessary to complete the structure as required by the Contract and in accordance with the Plans and these Specifications.

If shown on the Plans or in the Special Provisions, the Contractor shall dismantle the old structure on the bridge site in accordance with Item 101, Removal of Structures and Obstructions.

#### **403.3.13 Handling and Storing Materials**

Materials to be stored shall be placed on skids above the ground. It shall be kept clean and properly drained. Girders and beams shall be placed upright and shored. Long members, such as columns and chords, shall be supported on skids placed near enough together to prevent injury from deflection. If the Contract is for erection only, the Contractor shall check the material turned over to him against the shipping lists and report promptly in writing any shortage or damage discovered. He shall be responsible for the loss of any material while in his care, or for any damage caused to it after being received by him.

#### **403.3.14 Falsework**

The false work shall be properly designed and substantially constructed and maintained for the loads which will come upon it. The Contractor shall prepare and submit to the Engineer working drawings for falsework and working drawings for changes in any existing structure for maintaining traffic, in accordance with Clause 45 of Part G, Div. II, Vol. I.

#### **403.3.15 Method and Equipment**

Before starting the work of erection, the Contractor shall inform the Engineer fully as to the method of erection he proposes to follow, and the amount and character of equipment he proposes to use, which shall be subject to the approval of the Engineer. The approval of the Engineer shall not be considered as relieving the Contractor of the responsibility for the safety of his method or equipment or from carrying out the work in full accordance with the Plans and Specifications. No work shall be done until such approval by the Engineer has been obtained.

#### **403.3.16 Straightening Bent Materials**

The strengthening of plates, angles, other shapes and built-up members, when permitted by the Engineer, shall be done by methods that will not produce fracture or other injury. Distorted members shall be straightened by mechanical means or, if approved by the Engineer, by the carefully planned and supervised application of a limited amount of localized heat, except that heat straightening of AASHTO M 244 (ASTM A 514) or ASTM A 517 steel members shall be done only under rigidly controlled procedures, each application subject to the approval of the Engineer. In no case shall the maximum temperature of the AASHTO M 244 (ASTM A 514) or ASTM A 517 steels exceed  $607.2^{\circ}\text{C}$ , nor shall the temperature exceed  $510^{\circ}\text{C}$  at the weld metal or within 152.4 mm of weld metal. Heat shall not be applied directly on weld metal. In all other steels, the temperature of the heated area shall not exceed  $648.9^{\circ}\text{C}$  (a dull red) as controlled by temperature indicating crayons, liquids or bimetal thermometers.

Parts to be heat-straightened shall be substantially free of stress and from external forces, except stresses resulting from mechanical means used in conjunction with the application of heat.

Following the straightening of a bend or buckle, the surface of the metal shall be carefully inspected for evidence of fracture.

#### **403.3.17 Assembling Steel**



The parts shall be accurately assembled as shown on the working drawings and any matchmarks shall be followed. The material shall be carefully handled so that no parts will be bent, broken or otherwise damaged. Hammering which will injure or distort the members shall not be done. Bearing surfaces and surfaces to be in permanent contact shall be cleaned before the members are assembled. Unless erected by the cantilever methods, truss spans shall be erected on blocking so placed as to give the trusses proper camber. The blocking shall be left in place until the tension chord splices are fully connected with permanent fasteners and all other truss connections pinned and erection bolted. Splices of butt joints of compression members, that are milled to bear and of railing shall not be permanently fastened until the spans have been swung, except that such permanent fastening may be accomplished for the truss members at any time that joint holes are fair. Splices and field connections shall have one-half of the holes filled with erection bolts and cylindrical erection pins (half bolts and half pins) before placing permanent fasteners. Splices and connections carrying traffic during erection shall have three-fourths of the holes so filled, unless otherwise permitted by the Engineer.

Fitting-up bolts shall be of the same nominal diameter as the permanent fasteners and cylindrical erection pins will be 1.6 mm larger.

#### **403.3.18 Riveting**

Pneumatic hammers shall be used for field riveting except when the use of hand tools is permitted by the Engineer. Rivets larger than 15.9 mm in diameter shall not be driven by hand. Cup-faced dollies, fitting the head closely to insure good bearing, shall be used. Connections shall be accurately and securely fitted up before the rivets are driven.

Drifting shall be only such as to draw the parts into position and not sufficient to enlarge the holes or distort the metal. Unfair holes shall be reamed or drilled. Rivets shall be heated uniformly to a "light cherry red" color and shall be driven while hot. They shall not be overheated or burned. Rivet heads shall be full and symmetrical, concentric with the shank, and shall have full bearing all around. They shall not be smaller than the heads of the shop rivets. Rivets shall be tight and shall grip the connected parts securely together. Caulking or recupping will not be permitted. In removing rivets, the surrounding metal shall not be injured. If necessary, they shall be drilled out.

#### **403.3.19 Pin Connections**

Pilot and driving nuts shall be used in driving pins. They shall be furnished by the Contractor without charge. Pins shall be so driven that the members will take full bearing on them. Pin nuts shall be screwed up tight and the threads burred at the face of the nut with a pointed tool.

#### **403.3.20 Setting Shoes and Bearings**

Shoes and bearing shall not be placed on bridge seat bearing areas that are improperly finished, deformed, or irregular. They shall be set level in exact position and shall have full and even bearing. The shoes and bearing plates may be set by either of the following methods:

1. Method 1

The bridge seat bearing area shall be heavily coated with red lead paint and then covered with three layers of 405 to 472 g/m<sup>2</sup> duck, each layer being coated thoroughly on its top surface with red lead paint. The shoes and bearing plates shall be placed in position while the paint is plastic.

As alternatives to canvas and red lead, and when so noted on the Plans or upon written permission by the Engineer, the following may be used:

- a. Sheet lead of the designated thickness
- b. Preformed fabric pad composed of multiple layers of 270 g/m<sup>2</sup> duck impregnated and bound with high quality natural rubber or of equivalent and equally suitable materials compressed into resilient pads of uniform thickness. The number of plies shall be such as to produce the specified thickness, after compression and vulcanizing. The finished pads shall withstand compression loads perpendicular to the plane of the laminations of not less than 7 kg/mm<sup>2</sup> without detrimental reduction in thickness or extension.
- c. Elastomeric bearing pads

## 2. Method 2

The shoes and bearing plates shall be properly supported and fixed with grout. No load shall be placed on them until the grout has set for at least 96 hours, adequate provision being made to keep the grout well moistened during this period. The grout shall consist of one part Portland Cement to one part of fine-grained sand.

The location of the anchor bolts in relation to the slotted holes in expansion shoes shall correspond with the temperature at the time of erection. The nuts on anchor bolts at the expansion ends shall be adjusted to permit the free movement of the span.

### **403.3.21 Preparing Metal Surfaces for Painting**

All surfaces of new structural steel which are to be painted shall be blast cleaned unless otherwise specified in the Special Provisions or approved in writing by the Engineer.

In repainting existing structures where partial cleaning is required, the method of cleaning will be specified in the Special Provision.

The steel surfaces to be painted shall be prepared as outlined in the "Steel Structures Painting Council Specifications" (SSPC) meeting one of the following classes of surface preparation.

- a. SSPC – SP – 5 White Metal Blast Cleaning
- b. SSPC – SP – 6 Commercial Blast Cleaning
- c. SSPC – SP – 8 Pickling
- d. SSPC – SP – 10 Near White Blast Cleaning

Blast cleaning shall leave all surfaces with a dense and uniform anchor pattern of not less than one and one-half mills as measured with an approved surface profile comparator.

Blast cleaned surfaces shall be primed or treated the same day blast cleaning is done. If cleaned surface rust or are contaminated with foreign material before painting is accomplished, they shall be re-cleaned by the Contractor at his expense.

When paint systems No. 1 or 3 are specified, the steel surfaces shall be blast cleaned in accordance with SSPC – SP – 10. When paint systems No. 2, 4 or 5 are specified, the steel surface shall be blast cleaned in accordance with SSPC – SP – 6.

#### **403.3.22 System of Paint**

The paint system to be applied shall consist of one as set forth in Table 403.4 and as modified in the Special Provisions.

#### **403.3.23 Painting Metal Surfaces**

##### **1. Time of Application**

The prime coat of paint or pretreatment when specified, shall be applied as soon as possible after the surface has been cleaned and before deterioration of the surface occurs. Any oil, grease, soil, dust or foreign matter deposited on the surface after the surface preparation is completed shall be removed prior to painting. In the event the rusting occurs after completion of the surface preparation, the surfaces shall be again cleaned.

Particular care shall be taken to prevent the contamination of cleaned surfaces with salts, acids, alkali, or other corrosive chemicals before the prime coat is applied and between applications of the remaining coats of paint. Such contaminants shall be removed from the surface. Under these circumstances, the pretreatments or, in the absence of a pretreatment, the prime coat of paint shall be applied immediately after the surface has been cleaned.

##### **2. Storage of Paint and Thinner**

All paint and thinner should preferably be stored in a separate building or room that is well ventilated and free from excessive heat, sparks, flame or the direct ray of the sun.

All containers of paint should remain unopened until required for use. Containers which have been opened shall be used first.

Paint which has livered, gelled, or otherwise deteriorated during storage shall not be used. Thixotropic materials which may be stirred to attain normal consistency are satisfactory.

##### **3. Mixing and Thinning**

All ingredients in any container of paint shall be thoroughly mixed before use and shall be agitated often enough during application to keep the pigment in suspension.

Paint mixed in the original container shall not be transferred until all settled pigment is incorporated into the vehicle. This does not imply that part of the vehicle cannot be poured off temporarily to simplify the mixing.

Mixing shall be by mechanical methods, except that hard mixing will be permitted for container up to 19 litres in size.

Mixing in open containers shall be done in a well ventilated area away from sparks or flames.

Paint shall not be mixed or kept in suspension by means of an air stream bubbling under the paint surface.

When a skin has formed in the container, the skin shall be cut loose from the sides of the container, removed, and discarded. If such skins are thick enough to have a practical effect on the composition and quality of the paint, the paint shall not be used.

The paint shall be mixed in manner which will insure breaking up of all lumps, complete dispersion of settled pigment, and a uniform composition. If mixing is done by hand, most of the vehicle shall be poured off into a clean container. The pigment in the paint shall be lifted from the bottom of the container with a broad, flat paddle, lumps shall be broken up, and the pigment thoroughly mixed with the vehicle. The poured off vehicle shall be returned to the paint with simultaneous stirring, or pouring repeatedly from one container to another until the composition is uniform. The bottom of the container shall be inspected for unmixed pigment. Tinting pastes or colors shall be wetted with a small amount of thinner, vehicle, or paint and thoroughly mixed. The thinned mixture shall be added to the large container of paint and mixed until the color is uniform.

Paint which does not have a limited pot life, or does not deteriorate on standing, may be mixed at any time before using, but if settling has occurred, it must be remixed immediately before using. Paint shall not remain in spray pots, painter's buckets, etc., overnight, but shall be gathered into a container and remixed before use.

No thinner shall be added to the paint unless necessary for proper application. In no case shall more than 0.5 litres of thinner be added per 3.8 litres unless the paint is intentionally formulated for greater thinning.

The type of thinner shall comply with the paint specification.

When the use of thinner is permissible, thinner shall be added to paint during the mixing process. Painters shall not add thinner to paint after it has been thinned to the correct consistency.

All thinning shall be done under supervision of one acquainted with the correct amount and type of thinner to be added to the paint.

**Table 403.4 – Paint System**

	Paint System				
	1	2	3	4	5
High Pollution or Coastal	x	x	x		
Mild Climate				x	X

Note:

1. Paint system shown for severe areas are satisfactorily in less severe areas.
2. Coastal - within 304.8 m of ocean or tidal water.  
 High pollution-air pollution environment such as industrial areas.  
 Mild-other than coastal areas not in air pollution environment.

All structural steel shall be painted by one of the following systems. The required system or choice of systems will be shown in the Contract.

System 4 is intended for use in mild climates or to repaint existing structures where the other systems are not compatible.

Coating Thickness	Specifications	Min. Dry Film
<b>System 1 – Vinyl Paint System</b>		
Wash Prime	708.03 (b)	12.7
Intermediate Coat	708.03 (b)	38.10 – 50.80
3 <sup>rd</sup> Coat	708.03 (b)	38.10 – 50.80
4 <sup>th</sup> Coat	708.03 (b)	38.10 – 50.80
Finish Coat	708.03 (b)	38.10 – 50.80
Total thickness		165.10 – 203.20
<b>System 2 – Epoxy-Polyimide System</b>		
Prime Coat	708.03 (c)	50.80 – 76.20
Intermediate Coat	708.03 (c)	50.80 – 76.20
3 <sup>rd</sup> Coat	708.03 (c)	50.80 – 76.20
Finish Coat	708.03 (c)	38.10 – 50.80
Total thickness		190.50 – 279.40
* The third coat may be eliminated in mild climates		

Coating Thickness	Specifications	Min. Dry Film
<b>System 3 – Inorganic Zinc-Rich Coating System</b>		
Prime Coat	708.03(d)	88.90 – 127
Epoxy Intermediate Coat	708.03 (d)	40.80 – 76.20
Finish Coat	708.03 (d)	38.10 – 50.80
Total thickness		177.80 – 254
<b>Alternate System</b>		
Prime Coat	708.03 (d)	88.90 – 127
Wash Primer Tie Coat	708.03 (d)	12.70
Finish Coat	708.03 (d)	38.10 – 50.80
Total thickness		139.70 – 190.50
<b>System 4 – Alkyd-Oil-Basic Lead-Chromate System</b>		
Prime Coat	708.03 (e)	38.10 – 50.80
Intermediate Coat	708.03 (e)	38.10 – 50.80
Finish Coat	708.03 (e)	38.10 – 50.80
Total thickness		114.30 – 152.40
* The paint system may be specified as four coats for new structure steel in mild climate, with a minimum thickness of 152.40 mm.		
<b>System 5 – Organic Zinc-Rich Paint System</b>		

Prime Coat	708.03 (f)	38.10 – 50.80
Intermediate Coat	708.03 (f)	50.80 – 63.50
Wash Primer Tie Coat	708.03 (f)	12.70
Finish Coat	708.03 (f)	38.10 – 50.80
Total thickness		139.70 – 177.80

#### 4. Application of Paint

##### a. General

The oldest of each kind of paint shall be used first. Paint shall be applied by brushing or spraying or a combination of these methods. Daubers or sheepskins may be used when no other method is practicable for proper application in places of difficult access. Dipping, roller coating, or flow coating shall be used only when specifically authorized. All paints shall be applied in accordance with the manufacturer's instructions.

Open seams at contact surfaces of built up members which would retain moisture shall be caulked with red lead paste, or other approved material, before the second undercoat of paint is applied.

Paint shall not be applied when the surrounding air temperature is below 4.4°C. Paint shall not be applied when the temperature is expected to drop to 0°C before the paint has dried. Paint shall not be applied to steel at a temperature over 51.7°C unless the paint is specifically formulated for application at the proposed temperature, nor shall paint be applied to steel which is at a temperature that will cause blistering or porosity or otherwise will be detrimental to the life of the paint.

Paint shall not be applied in fog or mist, or when it is raining or when the relative humidity exceeds 85 percent. Paint shall not be applied to wet or damp surfaces.

When paint must be applied in damp or cold weather, the steel shall be painted under cover, or protected, or sheltered or the surrounding air and the steel heated to a satisfactory temperature. In such cases, the above temperature and humidity conditions shall be met. Such steel shall remain under cover or be protected until dry or until weather conditions permit its exposure.

Any applied paint exposed to excess humidity, rain or condensation shall first be permitted to dry. Then damaged areas of paint shall be removed, the surface again prepared and then repainted with the same number of coats of paint of the same kind as the undamaged areas.

If stripe painting is stipulated in the Special Provisions or if the Contractor chooses to do so at his option, all edges, corners, crevices, rivets, bolts, weld and sharp edges shall be painted with the priming paint by brush before the steel receives first full prime coat of paint. Such striping shall extend for at least 25.4 mm from the edge. When practicable, this stripe coat shall be permitted to dry before the prime coat is applied, otherwise the stripe coat shall set to touch before the full prime coat is applied. However, the stripe coat shall not be permitted to dry for a period of long enough to allow rusting of the unprimed steel. When desired, the stripe coat may be applied after a complete prime coat.

To the maximum extent practicable, each coat of paint shall be applied as continuous film of uniform thickness free of pores. Any thin spots or areas missed in the application shall be repainted and permitted to dry before the next coat of paint is applied. Film thickness is included in the description of paint systems. Each coat of paint shall be in a proper state of cure or dryness before application of the succeeding coat.

b. Brush Application

Paint shall be worked into all crevices and corners where possible and surfaces not accessible to brushes shall be painted by spray, doublers, or sheepskins. All runs or rags shall be brushed out. There shall be a minimum of brush marks left in the paint.

c. Spray Application of Paint

The equipment used for spray application of paint shall be suitable for the intended purpose, shall be capable of properly atomizing the paint to be applied and shall be equipped with suitable pressure regulators and gages. The air caps, nozzles, and needles shall be those recommended by the manufacturer of the equipment for the material being sprayed. The equipment shall be kept in satisfactory condition to permit proper paint application. In closed or recirculating paint spray system, where gas under pressure is used over the liquid, the gas shall be an inert, one such as nitrogen. Traps or separators shall be provided to remove oil and water from the compressed air. These traps or separators shall be adequate size and shall be drained periodically during operations. The air from the spray gun impinging against the surface shall show no water or oil.

Paint ingredients shall be kept properly mixed in the spray pots or containers during paint applications either by continuous mechanical agitation or by intermittent agitation as frequently as necessary.

The pressure on the material in the pot and of the air at the guns shall be adjusted for optimum spraying effectiveness. The pressure on the material in the pot shall be adjusted when necessary for changes in elevation of the gun above the pot. The atomizing air pressure at the gun shall be high enough to atomize the paint properly but not so high as to cause excessive fogging of paint, excessive evaporation of solvent or loss by overspray.

Spray equipment shall be kept sufficiently clean so that dirt, dried paint and other foreign material are not deposited in the paint film. Any solvents left in the equipment shall be completely removed before applying paint to the surface being painted.

Paint shall be applied in uniform layer, with overlapping at the edge of the spray pattern. The spray shall be adjusted so that the paint is deposited uniformly. During application, the gun shall be held perpendicular to the surface and at a distance which will insure that a wet layer of paint is deposited on the surface. The trigger of the gun should be released at the end of each stroke.

All runs and sags shall be brushed out immediately or the paint shall be removed and the surface repainted. Spray application of prime coats shall in all cases be immediately followed by brushing

Areas inaccessible to the spray gun shall be painted by brush, if not accessible by brush, daubers or sheepskins shall be used. Brushes shall be used to work paint into cracks, crevices and blind spots where are not adequately painted by spray.

d. Shop Painting

Shop painting shall be done after fabrication and before any damage to the surface occurs from weather or other exposure. Shop contact surfaces shall not be painted unless specified.

Surfaces not to be in contact but which will be inaccessible after assembly shall receive the full paint system specified or three shop coats of the specified before assembly.

The areas of steel surfaces to be in contact with concrete shall not be painted, unless otherwise shown on the Plans, the areas of steel surfaces to be in contact with wood shall receive either the full paint coats specified or three shop coats of the specified primer.

If paint would be harmful to a welding operator or would be detrimental to the welding operation or the finished welds, the steel shall not be painted within a suitable distance from the edges to be welded. Welding through inorganic zinc paint systems will not be permitted unless approved by the Engineer.

Antiweld spatter coatings shall be removed before painting. Weld slag and flux shall be removed by methods at least as effective as those specified for the cleaning.

Machine-finished or similar surfaces that are not to be painted, but do not require protections, shall be protected with a coating of rust inhibitive petroleum, other coating which may be more suitable, for special conditions.

Erection marks and weight marks shall be copied on area that have been previously painted with the shop coat.

e. Field Painting

Steel structures shall be painted as soon as practicable after erection.

Metal which has been shop coated shall be touched up with the same type of paints as the shop coat. This touch-up shall include cleaning and painting of field connections, welds, rivets and all damaged or defective paint and rusted areas. The Contractor may, at his option, apply an overall coat of primer in place of touch-up spot painting.

Surfaces (other than contact surfaces) which are accessible before erection but which will not be accessible after erection shall receive all field coats of paint before erection.

If possible the final coat of paint shall not be applied until all concrete work is finished. If concreting or other operations damage any paint, the surfaces shall be cleaned and repainted. All cement or concrete spatter and dripping shall be removed before any paint is applied.



Wet paint shall be protected against damage from dust or other detrimental foreign matter to the extent practicable.

f. Drying of Painted Metal

The maximum practicable time shall be allowed for paint to dry before recoating or exposure. No drier shall be added to paint on the job unless specifically called for in the Specifications for the paint. No painted metal shall be subjected to immersion before the paint is dried through. Paint shall be protected from rain, condensation, contamination, and freezing until dry, to the fullest extent practicable.

g. Handling of Painted Steel

Painted steel shall not be handled until the paint has dried, except for necessary handling in turning for painting or stacking for drying.

Paint which is damaged in handling shall be scraped off and touched-up with the same number of the coats and kinds of paint as were previously applied to the steel.

Painted steel shall not be loaded for shipment or shipped until it is dry.

Precautions shall be taken to minimize damage to paint films resulting from stocking members.

5. Measurement of Dry Film Thickness of Paints

a. Instrumentation

Dry paint film thickness shall be measured using Pull-Off (Type 1) or Fixed Probe (Type 2) Magnetic Gages. Type 1 gages include Tinsley, Elcometer, Microtest and Inspector models. Type 2 gage include Elcometric, Minitector, General Electric, Verimeter and Accuderm models.

b. Calibration

1. Type 1 (Pull-Off) Magnetic Gages

Measure the coating thickness on a series of reliable standards covering the expected range of paint thickness. Record the calibration correction either plus (+) or minus (-) required at each standard thickness. To guard against gage drift during use, re-check occasionally with one or more of the standards.

When the gage adjustment has drifted so far that large corrections are needed, it is advisable to re-adjust closer to the standard values and re-calibrate.

For Type 1 gages, the preferred basic standards are small, chromeplated steel panels that may be available from the National Bureau of Standards in coating thickness from 12.70 mm to 203.20 mm.

Plastic shims of certified thickness in the appropriate ranges may also be used to calibrate the gages. The gage is held firmly enough to press the shim tightly against the steel surface. Record the calibration correction as above.

## 2. Type 2 (Fixed Probe) Magnetic Gages

Shims of plastic or non-magnetic metals laid on the appropriate steel base (at least 76.2 x 76.2 x 3.2 mm) are suitable working standards. These gages are held firmly enough to press the shim tightly against the steel surface. One should avoid excessive pressure that might indent the plastic or, on a blast cleaned surface, might impress the steel peaks into the undersurface of the plastic.

The National Bureau of Standards – standards panels shall not be used to calibrate Type 2 gages.

### c. Measurement Procedures

To determine the effect of the substrate surface condition on the gage readings, access is required to some unpainted areas.

Repeated gage readings, even at points close together, may differ considerably due to small surface irregularities. Three gage readings should therefore be made for each spot measurement of either the substrate or the paint. Move the probe a short distance for each new gage reading. Discard any unusually high or low gage reading that cannot be repeated consistently. Take the average of the three gage readings as the spot measurement.

#### 1. Measurement with Type 1 (Pull-Off) Gage

Measure (A), the bare substrate, at a number of spots to obtain a representative average value. Measure (B), the dry paint film, at the specified number of spots.

Correct the (A) and (B) gage readings or averages as determined by calibration of the gage. Subtract the corrected readings (A) from (B) to obtain the thickness of the paint above the peaks of the surface.

#### 2. Measurement with Type 2 (Fixed Probe) Gage

Place a standard shim of the expected paint thickness on the bare substrate that is to be painted. Adjust the gage in place on the shim so that it indicates the known thickness of the shim.

Conform the gage setting by measuring the shim at several other area of the bare substrate. Re-adjust the gage as needed to obtain an average setting representative of the substrate.

With the gage adjustment as above, measure the dry paint film at three points. The gage readings indicate the paint film thickness at the three points. The gage readings indicate the paint thickness above the peaks of the surface profile.

Re-check the gage setting at frequent intervals during a long series of measurements. Make five separate spot measurements spaced evenly over each section of the structure 9.29 square metres in area, or of other area as may be specified. The average of five spot measurements for each such section shall not be less than the specified thickness. No single spot measurement (average of three readings) in any section shall be less than 80% of the specified thickness.

Since paint thickness is usually specified (or implied) as a minimum, greater thickness that does not cause defects of appearance or functions such as mud cracking, wrinkling, etc., is permitted unless otherwise specified.

d. Special Notes

All of the above magnetic, if properly adjusted and in good condition, are inherently accurate to within +15% of the true thickness of the coating.

Much larger, external errors may be caused by variations in method of use of the gages or by unevenness of the surface of the substrate or of the coating. Also, any other film present on the steel (rust or mill scale or even a blast cleaned profile zone) will add to the apparent thickness of the applied paint film.

The surface of the paint and the probe of the gage must be free from dust, grease and other foreign matter in order to obtain close contact of the probe with the paint and also to avoid adhesion of the magnet. The accuracy of the measurement will be affected if the coating is tacky or excessively soft.

The magnetic gages are sensitive to geometrical discontinuities of the steel, as at holes, corners or edges. The sensitivity to edge effects and discontinuities varies from gage to gage. Measurements closer than 25.4 mm from the discontinuity may not be valid unless the gage is calibrated specifically for that location.

Magnetic gage readings also may be affected by proximity to another mass of steel close to the body of the gage, by surface curvature and presence of other magnetic fields.

All of the magnets or probe must be held perpendicular to the painted surface to produce valid measurements.

#### **403.3.24 Clean-up**

Upon completion and before final acceptance, the Contractor shall remove all falsework, falsework piling down to at least 609.6 mm below the finished ground line, excavated or unused materials, rubbish and temporary buildings. He shall replace or renew any fences damaged and restored in an acceptable manner all property, both public and private, which may have been damaged during the prosecution of the work and shall leave the work site and adjacent highway in a neat and presentable condition, satisfactory to the Engineer. All excavated material or falsework placed in the stream channel during construction shall be removed by the Contractor before final acceptance.

#### **403.4 Method of Measurement**

#### 403.4.1 Unit Basis

The quantity of structural steel to be paid for shall be the number of kilos complete in place and accepted. For the purpose of measurement for payment components fabricated from metals listed in (1) below, such as casting, alloy steels, steel plates, anchor bolts and nuts, shoes, rockers, rollers, pins and nuts, expansion dams, roadway drains and souppers, welds metal, bolts embedded in concrete, cradles and brackets, posts, conduits and ducts, and structural shapes for expansion joints and pier protection will be considered as structural steel.

Unless otherwise provided, the mass of metal paid for shall be computed and based upon the following mass:

##### 1. Unit Density kg/m<sup>3</sup>

Aluminum, cast or rolled	2771.2
Bronze or copper alloy	8585.9
Copper sheet	8938.3
Iron, cast	7128.2
Iron, malleable	7528.7
Lead, sheet	11229
Steel, cast or rolled, including alloy copper bearing and stainless	7849
Zinc	7208.3

##### 2. Shapes, Plates Railing and Flooring

The mass of steel shapes and plates shall be computed on the basis of their nominal mass and dimensions as shown on the approved shop drawings, deducting for copes, cuts and open holes, exclusive of rivets holes. The mass of all plates shall be computed on the basis of nominal dimensions with no additional for overrun.

The mass of railing shall be included as structural steel unless the Bill of Quantities contains as pay item for bridge railing under Item 401, Railings.

The mass of steel grid flooring shall be computed separately.

##### 3. Casting

The mass of casting shall be computed from the dimensions shown on the approved drawings, deducting for open holes. To this mass will be added 5 percent allowable for fillets and overruns. Scale mass may be substituted for computed mass in the case of castings of small complex parts for which accurate computations of mass would be difficult.

##### 4. Miscellaneous

The mass of erection bolts, shop and field paint, galvanizing the boxes, crates and other containers used for shipping, together with sills, struts, and rods used for supporting members during the transportation, bridge hardware as defined in Subsection 402.2.2 excluding steel

plates and bearings, connectors used for joining timber members, nails, spikes and bolts, except anchor bolts will be excluded.

5. Rivets Heads

The mass of all rivet heads, both files and shop, will be assumed as follows:

<b>Diameter of rivet (mm)</b>		<b>kg per 100 heads</b>
12.7		1.80
15.9		3.20
19.0		5.44
22.2		8.16
25.4		11.80
28.6		16.33
31.7		21.8

6. High-Strength Bolts

High-strength steel bolts shall be considered for purpose of payment, the same as rivets of the same diameter, with the mass of the bolt heads and nuts the same as the corresponding rivet heads.

7. Welds

The mass of shop and field fillet welds shall be assumed as follows:

<b>Size of Weld (mm)</b>		<b>kg per linear metre</b>
6.3		0.984
7.9		1.213
9.5		1.771
12.7		2.690
5.9		3.936
19.0		5.379
22.2		7.314
25.4		9.774

The mass of other welds will be computed on the basis of the theoretical volume from dimensions of the welds, with an addition of 50 mass percent as an allowance for overrun.

8. Other Items

The quantities of other Contract Items which enter into the completed and accepted structure shall be measured for payment in the manner prescribed for the Items involved.

**403.4.2 Lump Sum Basis**

Lump sum will be the basis of payment unless noted otherwise in the bidding documents. No measurements of quantities will be made except as provided in Subsection 403.5.1 (4).

## **403.5 Basis of Payment**

### **403.5.1 Structural Steel**

#### **1. Furnished, Fabricated and Erected**

The quantity, determined as provided above, shall be paid for at the contract unit price per kilogram for “Structural Steel, furnished, fabricated and erected”, which price and payment shall constitute full compensation for furnishing, galvanizing, fabricating, radiographing, magnetic particle inspection, delivering, erecting ready for use, and painting all steel and other metal including all labor, equipment, tools and incidentals necessary to complete the work, except as provided in Subsections 403.5.2, 403.5.3 and 403.5.4.

#### **2. Furnished and Fabricated**

When a quantity and unit price for “Structural Steel, furnished and fabricated” are shown in the Bill of Quantities, the quantity, determined as provided above, will be paid for at the contract unit price per kilogram which price and payment shall be full compensation for furnishing, galvanizing, fabricating, radiographing, magnet particle inspection, shop painting and delivering the structural steel and other metal free of charges at the place designated in the Special Provisions and for all labor, equipment, tools and incidentals necessary to complete the work, save erection and except as provided in Subsection 403.5.2, 403.5.3 and 403.5.4.

#### **3. Erected**

When a quantity and unit price for “Structural Steel Erected” are shown in the Bill of Quantities, the quantity, determined as provided above, will be paid for at the said contract unit price per kilogram which price and payment shall be full compensation for unloading all the structural steel and other metal, payment of any demurrage charges, transporting to the bridge site, erecting, magnetic particle inspection and radiographing, complete ready for use including furnishing and applying the field paint including all labor, equipment, tools and incidentals necessary to complete the work, save furnishing and fabrication, and except as provided in Subsections 403.5.2, 403.5.3 and 403.5.4.

#### **4. Lump Sum**

When the Bill of Quantities calls for lump sum price for “Structural Steel, furnished, fabricated and erected”, the Item will be paid for at the contract lump sum price and payment shall be full compensation for furnishing, fabricating and erecting material and for all work herein before prescribed in connection therewith, including all labor, equipment, tools and incidentals necessary to complete the work, except as provided in Subsections 403.5.2, 403.5.3 and 403.5.4.

The estimate of the mass of structural steel shown on the Plans is approximate only and no guarantee is made that it is the correct mass to be furnished. No adjustment in the contract price will be made if the mass furnished is more or less than estimated mass.

If changes in the work are ordered by the Engineer, which vary the mass of steel to be furnished, the lump sum payment shall be adjusted as follows:

- a. The value per kilogram of the increase or decrease in mass of structural steel involved in the change shall be determined by dividing the contract lump sum amount by the estimate of mass shown on the Plans. The adjusted contract lump sum payment shall be the contract lump sum plus or minus the value of the steel involved in the change, and no additional compensation shall be made on account of said change.
- b. Full-size members which are tested in accordance with the Specifications when such tests are required by the Contract, shall be paid for at the same rate as for comparable members in the structure. Members which fail to meet the Contract requirements, and members rejected as a result of test shall not be paid for.

**403.5.2 Material Considered as Structural Steel**

For the purpose of Subsection 403.5.1 and unless otherwise shown on the Plans, castings, forgings, special alloy steels and steel plates, wrought iron, and structural shapes of expansion joints and pier protection shall be considered as structural steel except that when quantities and unit price for certain alloy steels, forgings, castings or other specific categories of metal are called for in the Bill of Quantities, the mass of such selected material, determined as provided above, shall be paid for at the respective contract unit price per kilogram for “Structural Steel (Alloy steel, forgings, castings, and/or other category), furnished and fabricated, and erected” or “Structural Steel (Subsection 403.4.1), furnished and fabricated” as named in the Bill of Quantities.

**403.5.3 Other Items**

The quantities of all other Contract Items which enter into the completed and accepted structure shall be paid for at the contract unit prices for the several Pay Items as prescribed for the Items involved.

**403.5.4 Payment as Reinforcing Steel**

When the Bill of Quantities does not contain a pay item for structural steel, the quantities of metal drains, scuppers, conduits, ducts and structural shapes for expansion joints and pier protection, measured as provided above will be paid for as Reinforcing Steel under Item 404.

Payment will be made under:

Pay Item Number	Description	Unit of Measurement
403 (1)	Structural Steel, furnished, fabricated and erected	kilogram
403 (2)	Structural Steel, furnished, fabricated and erected	kilogram

403 (3)	Structural Steel, furnished, fabricated	kilogram
---------	--	----------

**ITEM 404 – REINFORCING STEEL**

**404.1 Description**

This Item shall consist of furnishing, bending, fabricating and placing of steel reinforcement of the type, size, shape and grade required in accordance with this Specification and in conformity with the requirements shown on the Plans or as directed by the Engineer.

**404.2 Material Requirements**

Reinforcing steel shall meet the requirements of item 710, Reinforcing Steel and Wire Rope.

**4.4.3 Construction Requirements**

**404.3.1 Order Lists**

Before materials are ordered, all order lists and bending diagrams shall be furnished by the Contractor, for approval of the Engineer. The approval of order lists and bending diagrams by the Engineer shall in no way relieve the Contractor of responsibility for the correctness of such lists and diagrams. Any expense incident to the revisions of materials furnished in accordance with such lists and diagrams to make them comply with the Plans shall be borne by the Contractor.

**404.3.2 Protection of Material**

Steel reinforcement shall be stored above the surface of the ground upon platforms, skids, or other supports and shall be protected as far as practicable from mechanical injury and surface deterioration caused by exposure to conditions producing rust. When placed in the work, reinforcement shall be free from dirt, detrimental rust, loose scale, paint, grease, oil, or other foreign materials. Reinforcement shall be free from injurious defects such as cracks and laminations. Rust, surface seams, surface irregularities or mill scale will not be cause for rejection, provided the minimum dimensions, cross sectional area and tensile properties of a hand wire brushed specimen meets the physical requirements for the size and grade of steel specified.

**404.3.3 Bending**

All reinforcing bars requiring bending shall be cold-bent to the shapes shown on the Plans or required by the Engineer. Bars shall be bent around a circular pin having the following diameters (D) in relation to the diameter of the bar (d):

Nominal diameter, d, mm	Pin diameter (D)
10 to 20	6d
25 to 28	8d
32 and greater	10d



Bends and hooks in stirrups or ties may be bent to the diameter of the principal bar enclosed therein.

#### **404.3.4 Placing and Fastening**

All steel reinforcement shall be accurately placed in the position shown on the Plans or required by the Engineer and firmly held there during the placing and setting of the concrete. Bars shall be tied at all intersections except where spacing is less than 300mm in each directions, in which case, alternate intersections shall be tied. Ties shall be fastened on the inside.

Distance from the forms shall be maintained by means of stays, blocks, ties, hangers, or other approved supports, so that it does not vary from the position indicated on the Plans by more than 6mm. Blocks for holding reinforcement from contact with the forms shall be precast mortar blocks of approved shapes and dimensions. Layers of bars shall be separated by precast mortar blocks or by other equally suitable devices. The use of pebbles, pieces of broken stone or brick, metal pipe and wooden blocks shall not be permitted. Unless otherwise shown on the Plans or required by the Engineer, the minimum distance between bars shall be 40mm. Reinforcement in any member shall be placed and then inspected and approved by the Engineer before the placing of concrete begins. Concrete placed in violation of this provision may be rejected and removal may be required. If fabric reinforcement is shipped in rolls, it shall be straightened before being placed. Bundled bars shall be tied together at not more than 1.8m intervals.

#### **404.3.5 Splicing**

All reinforcement shall be furnished in the full lengths indicated on the Plans. Splicing of bars, except where shown on the Plans, will not be permitted without the written approval of the Engineer. Splices shall be staggered as far as possible and with a minimum separation of not less than 40 bar diameters. Not more than one-third of the bars may be spliced in the same cross-section, except where shown on the Plans.

Unless otherwise shown on the Plans, bars shall be lapped a minimum distance of:

Splice Type	Grade 40 min. lap	Grade 60 min. lap	But not less than
Tension	24 bar dia	36 bar dia	300 mm
Compression	20 bar dia	24 bar dia	300 mm

In lapped splices, the bars shall be placed in contact and wired together. Lapped splices will not be permitted at locations where the concrete section is insufficient to provide minimum clear distance of one and one-third the maximum size of coarse aggregate between the splice and the nearest adjacent bar. Welding of reinforcing steel shall be done only if detailed on the Plans or if authorized by the Engineer in writing. Spiral reinforcement shall be spliced by lapping at least one and a half turns or by butt welding unless otherwise shown on the Plans.

#### **404.3.6 Lapping of Bar Mat**

Sheets of mesh or bar mat reinforcement shall overlap each other sufficiently to maintain a uniform strength and shall be securely fastened at the ends and edges. The overlap shall not be less than one mesh in width.

#### **404.4 Method of Measurement**

The quantity of reinforcing steel to be paid for will be the final quantity placed and accepted in the completed structure.

No allowance will be made for tie-wires, separators, wire chairs and other material used in fastening the reinforcing steel in place. If bars are substituted upon the Contractor's request and approved by the Engineer and as a result thereof more steel is used than specified, only the mass specified shall be measured for payment.

No measurement or payment will be made for splices added by the Contractor unless directed or approved by the Engineer.

When there is no item for reinforcing steel in the Bill of Quantities, costs will be considered as incidental to the other items in the Bill of Quantities.

#### **404.5 Basis of Payment**

The accepted quantity, measured as prescribed in Section 404.4, shall be paid for at the contract unit price for Reinforcing Steel which price and payment shall be full compensation for furnishing and placing all materials, including all labor, equipment, tools and incidentals necessary to complete the work prescribed in this Item.

Payment will be made under:

Pay Item Number	Description	Unit of Measurement
404	Reinforcing Steel	Kilogram

### ***ITEM 405 – STRUCTURAL CONCRETE***

#### **405.1 Description**

##### **405.1.1 Scope**

This Item shall consist of furnishing, bending, placing and finishing concrete in all structures except pavements in accordance with this Specification and conforming to the lines, grades, and dimensions shown on the Plans. Concrete shall consist of a mixture of Portland Cement, fine aggregate, coarse aggregate, admixture when specified, and water mixed in the proportions specified or approved by the Engineer.

##### **405.1.2 Classes and Uses of Concrete**

Five classes of concrete are provided for in this Item, namely: A, B, C, P and Seal. Each class shall be used in that part of the structure as called for on the Plans.

The classes of concrete will generally be used as follows:

Class A – All superstructures and heavily reinforced substructures. The important parts of the structure included are slabs, beams, girders, columns, arch ribs, box culverts, reinforced abutments, retaining walls, and reinforced footings.

Class B – Footings, pedestals, massive pier shafts, pipe bedding, and gravity walls, unreinforced or with only a small amount of reinforcement.

Class C – Thin reinforced sections, railings, precast R.C. piles and cribbing and for filler in steel grid floors.

Class P – Prestressed concrete structures and members.

Seal – Concrete deposited in water.

## 405.2 Material Requirements

### 405.2.1 Portland Cement

It shall conform to all the requirements of Subsection 311.2.1.

### 405.2.2 Fine Aggregate

It shall conform to all the requirements of Subsection 311.2.2.

### 405.2.3 Coarse Aggregate

It shall conform all the requirements of Subsection 311.2.3 except that gradation shall conform to Table 405.1.

**Table 405.1 – Grading Requirements for Coarse Aggregate**

Sieve Designation		Mass Percent Passing				
Standard Mm	Alternate US Standard	Class A	Class B	Class C	Class P	Class Seal
63	2-1/2"		100			
50	2"	100	95 – 100			
37.5	1-1/2"	95 – 100	-			100
25	1"	-	35 – 70		100	95 – 100
19.0	3/4"	35 – 70	-	100	95 – 100	-
12.5	1/2"	-	10 – 30	90 – 100	-	25 – 60
9.5	3/8"	10 – 30	-	40 – 70	20 – 55	-
4.75	No.4	0 - 5	0 - 5	0 – 15*	0 – 10*	0 – 10*

\* The measured cement content shall be within plus (+) or minus (-) 2 mass percent of the design cement content.

#### **405.2.4 Water**

It shall conform to the requirements of Subsection 311.2.4

#### **405.2.5 Reinforcing Steel**

It shall conform to the requirements of Item 710, Reinforcing Steel and Wire Rope.

#### **405.2.6 Admixtures**

Admixtures shall conform to the requirements of Subsection 311.2.7

#### **405.2.7 Curing Materials**

Curing materials shall conform to the requirements of Subsection 311.2.8.

#### **405.2.8 Expansion Joint Materials**

Expansion joint materials shall be:

1. Preformed Sponge Rubber and Cork, conforming to AASHTO M 153.
2. Hot-Poured Elastic Type, conforming to AASHTO M 173.
3. Preformed Fillers, conforming to AASHTO M 213.

#### **405.2.9 Elastomeric Compression Joint Seals**

These shall conform to AASHTO M 220.

#### **405.2.10 Elastomeric Bearing Pads**

These shall conform to AASHTO M 251 or Item 412 – Elastomeric Bearing Pads.

#### **405.2.11 Storage of Cement and Aggregates**

Storage of cement and aggregates shall conform to all the requirements of Subsection 311.2.10.

### **405.3 Sampling and Testing of Structural Concrete**

As work progresses, at least one (1) sample consisting of three (3) concrete cylinder test specimens, 150 x 300mm (6 x 12 inches), shall be taken from each seventy five (75) cubic meters of each class of concrete or fraction thereof placed each day.

Compliance with the requirements of this Section shall be determined in accordance with the following standard methods of AASHTO:

Sampling of fresh concrete	T 141
Weight per cubic metre and air content (gravimetric) of concrete	T 121
Sieve analysis of fine and coarse aggregates	T 27
Slump of Portland Cement Concrete	T 119
Specific gravity and absorption of fine aggregate	T 84

Tests for strength shall be made in accordance with the following:

Making and curing concrete compressive and flexural tests specimens in the field	T 23
Compressive strength of molded concrete Cylinders	T 22

#### 405.4 Production Requirements

##### 405.4.1 Proportioning and Strength of Structural Concrete

The concrete materials shall be proportioned in accordance with the requirements for each class of concrete as specified in Table 405.2, using the absolute volume method as outlined in the American Concrete Institute (ACI) Standard 211.1. "Recommended Practice for Selecting Proportions for Normal and Heavyweight Concrete". Other methods of proportioning may be employed in the mix design with prior approval of the Engineer. The mix shall either be designed or approved by the Engineer. A change in the source of materials during the progress of work may necessitate a new mix design.

The strength requirements for each class of concrete shall be as specified in Table 405.2.

**Table 405.2 - Composition and Strength of Concrete for Use in Structures**

Class Of Concrete	Minimum Cement Content Per m <sup>3</sup> kg (bag**)	Maximum Water/Cement Ratio kg/kg	Consistency Range in Slump mm (inch)	Designated Size of Coarse Aggregate Square Opening Std. mm	Minimum Compressive Strength of 150x300mm Concrete Cylinder Specimen at 28 days, MN/m <sup>2</sup> (psi)
A	360 (9 bags)	0.53	50 – 100 (2 – 4)	37.5 – 4.75 (1-1/2" – No. 4)	20.7 (3000)
B	320 (8 bags)	0.58	50 – 100 (2 – 4)	50 – 4.75 (2" – No. 4)	16.5 (2400)
C	380	0.55	50 – 100	12.5 – 4.75	20.7

	(9.5 bags)		(2 – 4)	(1/2" – No. 4)	(3000)
P	440 (11 bags)	0.49	100 max. (4 max.)	19.0 – 4.75 (3/4" – No. 4)	37.7 (5000)
Seal	380 (9.5 bags)	0.58	100 – 200 (4 - 8)	25 – 4.75 (1" – No. 4)	20.7 (3000)

\* The measured cement content shall be within plus or minus 2 mass percent of the design cement content.

\*\* Based on 40 kg/bag

#### 405.4.2 Consistency

Concrete shall have a consistency such that it will be workable in the required position. It shall be of such a consistency that it will flow around reinforcing steel but individual particles of the coarse aggregate when isolated shall show a coating of mortar containing its proportionate amount of sand. The consistency of concrete shall be gauged by the ability of the equipment to properly place it and not by the difficulty in mixing and transporting. The quantity of mixing water shall be determined by the Engineer and shall not be varied without his consent. Concrete as dry as it is practical to place with the equipment specified shall be used.

#### 405.4.3 Batching

Measuring and batching of materials shall be done at a batching plant.

##### 1. Portland Cement

Either sacked or bulk cement may be used. No fraction of a sack of cement shall be used in a batch of concrete unless the cement is weighed. All bulk cement shall be weighed on an approved weighing device. The bulk cement weighing hopper shall be properly sealed and vented to preclude dusting operation. The discharge chute shall not be suspended from the weighing hopper and shall be so arranged that cement will neither be lodged in it nor leak from it.

Accuracy of batching shall be within plus (+) or minus (-) 1 mass percent.

##### 2. Water

Water may be measured either by volume or by weight. The accuracy of measuring the water shall be within a range of error of not more than 1 percent.

##### 3. Aggregates

Stockpiling of aggregates shall be in accordance with Subsection 311.2.10. All aggregates whether produced or handled by hydraulic methods or washed, shall be stockpiled or binned for draining for at least 12 hours prior to batching. Rail shipment requiring more than 12 hours will be accepted as adequate binning only if the car bodies permit free drainage. If the

aggregates contain high or non-uniform moisture content, storage or stockpile period in excess of 12 hours may be required by the Engineer.

Batching shall be conducted as to result in a 2 mass percent maximum tolerance for the required materials.

#### 4. Bins and Scales

The batching plant shall include separate bins for bulk cement, fine aggregate and for each size of coarse aggregate, a weighing hopper, and scales capable of determining accurately the mass of each component of the batch.

Scales shall be accurate to one-half (0.5) percent throughout the range used.

#### 5. Batching

When batches are hauled to the mixer, bulk cement shall be transported either in waterproof compartments or between the fine and coarse aggregate. When cement is placed in contact with moist aggregates, batches will be rejected unless mixed within 1-1/2 hours of such contact. Sacked cement may be transported on top of the aggregates.

Batches shall be delivered to the mixer separate and intact. Each batch shall be dumped cleanly into the mixer without loss, and, when more than one batch is carried on the truck, without spilling of material from one batch compartment into another.

#### 6. Admixtures

The Contractor shall follow an approved procedure for adding the specified amount of admixture to each batch and will be responsible for its uniform operation during the progress of the work. He shall provide separate scales for the admixtures which are to be proportioned by weight, and accurate measures for those to be proportioned by volume. Admixtures shall be measured into the mixer with an accuracy of plus or minus three (3) percent.

The use of Calcium Chloride as an admixture will not be permitted.

### **405.4.4 Mixing and Delivery**

Concrete may be mixed at the site of construction, at a central point or by a combination of central point and truck mixing or by a combination of central point mixing and truck agitating. Mixing and delivery of concrete shall be in accordance with the appropriate requirements of AASHTO M 157 except as modified in the following paragraphs of this section, for truck mixing or a combination of central point and truck mixing or truck agitating. Delivery of concrete shall be regulated so that placing is at a continuous rate unless delayed by the placing operations. The intervals between delivery of batches shall not be so great as to allow the concrete in place to harden partially, and in no case shall such an interval exceed 30 minutes.

In exceptional cases and when volumetric measurements are authorized, for small project requiring less than 75 cu.m. per day of pouring, the weight proportions shall be converted to equivalent volumetric proportions. In such cases, suitable allowance shall be made for

variations in the moisture condition of the aggregates, including the bulking effect in the fine aggregate. Batching and mixing shall be in accordance with ASTM C 685, Section 6 through 9.

Concrete mixing, by chute is allowed provided that a weighing scales for determining the batch weight will be used.

For batch mixing at the site of construction or at a central point, a batch mixer of an approved type shall be used. Mixer having a rated capacity of less than a one-bag batch shall not be used. The volume of concrete mixed per batch shall not exceed the mixer's nominal capacity as shown on the manufacturer's standard rating plate on the mixer except that an overload up to 10 percent above the mixer's nominal capacity may be permitted, provided concrete test data for strength, segregation, and uniform consistency are satisfactory and provided no spillage of concrete takes place. The batch shall be so charge into the drum that a portion of the water shall enter in advance of the cement and aggregates. The flow of water shall be uniform and all water shall be in the drum by the end of the first 15 seconds of the mixing period. Mixing time shall be measured from the time all materials, except water, are in the drum. Mixing time shall not be less than 60 seconds for mixers having a capacity of 1.5m<sup>3</sup> or less. For mixers having a capacity greater than 1.5m<sup>3</sup>, the mixing time shall not be less than 90 seconds. If timing starts, the instant the skip reaches its maximum raised position, 4 seconds shall be added to the specified mixing time. Mixing time ends when the discharge chute opens.

The mixer shall be operated at the drum speed as shown on the manufacturer's name plate on the mixer. Any concrete mixed less than the specified time shall be discarded and disposed off by the Contractor at his own expenses.

The timing device on stationary mixers shall be equipped with a bell or other suitable warning device adjusted to give a clearly audible signal each time the lock is released. In case of failure of the timing device, the Contractor will be permitted to continue operations while it is being repaired, provided he furnishes an approved timepiece equipped with minute and second hands. If the timing device is not placed in good working order within 24 hours, further use of the mixer will be prohibited until repairs are made.

Retempering concrete will not be permitted. Admixtures for increasing the workability, for retarding the set, or for accelerating the set or improving the pumping characteristics of the concrete will be permitted only when specifically provided for in the Contract, or authorized in writing by the Engineer.

#### 1. Mixing Concrete: General

Concrete shall be thoroughly mixed in a mixer of an approved size and type that will insure a uniform distribution of the materials throughout the mass.

All concrete shall be mixed in mechanically operated mixers. Mixing plant and equipment for transporting and placing concrete shall be arranged with an ample auxiliary installation to provide a minimum supply of concrete in case of breakdown of machinery or in case the normal supply of concrete is disrupted. The auxiliary supply of concrete shall be sufficient to complete the casting of a section up to a construction joint that will meet the approval of the Engineer.



Equipment having components made of aluminum or magnesium alloys, which would have contact with plastic concrete during mixing, transporting or pumping of Portland Cement concrete, shall not be used.

Concrete mixers shall be equipped with adequate water storage and a device of accurately measuring and automatically controlling the amount of water used.

Materials shall be measured by weighing. The apparatus provided for weighing the aggregates and cement shall be suitably designed and constructed for this purpose. The accuracy of all weighing devices except that for water shall be such that successive quantities can be measured to within one percent of the desired amounts. The water measuring device shall be accurate to plus or minus 0.5 mass percent. All measuring devices shall be subject to the approval of the Engineer. Scales and measuring devices shall be tested at the expense of the Contractor as frequently as the Engineer may deem necessary to insure their accuracy.

Weighing equipment shall be insulated against vibration or movement of other operating equipment in the plant. When the entire plant is running, the scale reading at cut-off shall not vary from the weight designated by the Engineer more than one mass percent for cement, 1-1/2 mass percent for any size of aggregate, or one (1) mass percent for the total aggregate in any batch.

## 2. Mixing Concrete at Site

Concrete mixers may be of the revolving drum or the revolving blade type and the mixing drum or blades shall be operated uniformly at the mixing speed recommended by the manufacturer. The pick-up and throw-over blades of mixers shall be restored or replaced when any part or section is worn 20mm or more below the original height of the manufacturer's design. Mixers and agitators which have an accumulation of hard concrete or mortar shall not be used.

When bulk cement is used and volume of the batch is 0.5m<sup>3</sup> or more, the scale and weigh hopper for Portland Cement shall be separate and distinct from the aggregate hopper or hoppers. The discharge mechanism of the bulk cement weigh hopper shall be interlocked against opening before the full amount of cement is in the hopper. The discharging mechanism shall also be interlocked against opening when the amount of cement in the hopper is underweight by more than one (1) mass percent or overweight by more than 3 mass percent of the amount specified.

When the aggregate contains more water than the quantity necessary to produce a saturated surface dry condition, representative samples shall be taken and the moisture content determined for each kind of aggregate.

The batch shall be so charged into the mixer that some water will enter in advance of cement and aggregate. All water shall be in the drum by the end of the first quarter of the specified mixing time.

Cement shall be batched and charged into the mixer so that it will not result in loss of cement due to the effect of wind, or in accumulation of cement on surface of conveyors or hoppers, or in other conditions which reduce or vary the required quantity of cement in the concrete mixture.

The entire content of a batch mixer shall be removed from the drum before materials for a succeeding batch are placed therein. The materials composing a batch except water shall be deposited simultaneously into the mixer.

All concrete shall be mixed for a period of not less than 1-1/2 minutes after all materials, including water, are in the mixer. During the period of mixing, the mixer shall operate at the speed for which it has been designed.

Mixers shall be operated with an automatic timing device that can be locked by the Engineer. The time device and discharge mechanics shall be so interlocked that during normal operation no part of the batch will be charged until the specified mixing time has elapsed.

The first batch of concrete materials placed in the mixer shall contain a sufficient excess of cement, sand, and water to coat inside of the drum without reducing the required mortar content of the mix. When mixing is to cease for a period of one hour or more, the mixer shall be thoroughly cleaned.

### 3. Mixing Concrete at Central Plant

Mixing at central plant shall conform to the requirements for mixing at the site.

### 4. Mixing Concrete in Truck

Truck mixers, unless otherwise authorized by the Engineer, shall be of the revolving drum type, water-tight, and so constructed that the concrete can be mixed to insure a uniform distribution of materials throughout the mass. All solid materials for the concrete shall be accurately measured and charged into the drum at the proportioning plant. Except as subsequently provided, the truck mixer shall be equipped with a device by which the quantity of water added can be readily verified. The mixing water may be added directly to the batch, in which case a tank is not required. Truck mixers may be required to be provided with a means of which the mixing time can be readily verified by the Engineer.

The maximum size of batch in truck mixers shall not exceed the minimum rated capacity of the mixer as stated by the manufacturer and stamped in metal on the mixer. Truck mixing, shall, unless other-wise directed be continued for not less than 100 revolutions after all ingredients, including water, are in the drum. The mixing speed shall not be less than 4 rpm, nor more than 6 rpm.

Mixing shall begin within 30 minutes after the cement has been added either to the water or aggregate, but when cement is charged into a mixer drum containing water or surface wet aggregate and when the temperature is above 32°C, this limit shall be reduced to 15 minutes. The limitation in time between the introduction of the cement to the aggregate and the beginning of the mixing may be waived when, in the judgement of the Engineer, the aggregate is sufficiently free from moisture, so that there will be no harmful effects on the cement.

When a truck mixer is used for transportation, the mixing time specified in Subsection 405.4.4 (3) at a stationary mixer may be reduced to 30 seconds and the mixing completed in a truck mixer. The mixing time in the truck mixer shall be as specified for truck mixing.

## 5. Transporting Mixed Concrete

Mixed concrete may only be transported to the delivery point in truck agitators or truck mixers operating at the speed designated by the manufacturers of the equipment as agitating speed, or in non-agitating hauling equipment, provided the consistency and workability of the mixed concrete upon discharge at the delivery point is suitable point for adequate placement and consolidation in place.

Truck agitators shall be loaded not to exceed the manufacturer's guaranteed capacity. They shall maintain the mixed concrete in a thoroughly mixed and uniform mass during hauling.

No additional mixing water shall be incorporated into the concrete during hauling or after arrival at the delivery point.

The rate of discharge of mixed concrete from truck mixers or agitators shall be controlled by the speed of rotation of the drum in the discharge direction with the discharge gate fully open.

When a truck mixer or agitator is used for transporting concrete to the delivery point, discharge shall be completed within one hour, or before 250 revolutions of the drum or blades, whichever comes first, after the introduction of the cement to the aggregates. Under conditions contributing to quick stiffening of the concrete or when the temperature of the concrete is 30°C, or above, a time less than one hour will be required.

## 6. Delivery of Mixed Concrete

The Contractor shall have sufficient plant capacity and transportation apparatus to insure continuous delivery at the rate required. The rate of delivery of concrete during concreting operations shall be such as to provide for the proper handling, placing and finishing of the concrete. The rate shall be such that the interval between batches shall not exceed 20 minutes. The methods of delivering and handling the concrete shall be such as will facilitate placing of the minimum handling.

### **405.5 Method of Measurement**

The quantity of structural concrete to be paid for will be the final quantity placed and accepted in the completed structure. No deduction will be made for the volume occupied by pipe less than 100mm (4 inches) in diameter or by reinforcing steel, anchors, conduits, weep holes or expansion joint materials.

### **405.6 Basis of Payment**

The accepted quantities, measured as prescribed in Section 405.5, shall be paid for at the contract unit price for each of the Pay Item listed below that is included in the Bill of Quantities.

Payment shall constitute full compensation for furnishing, placing and finishing concrete including all labor, equipment, tools and incidentals necessary to complete the work prescribed in the item.

Payment will be made under:

Pay Item Number	Description	Unit of Measurement
405 (1)	Structural Concrete, Class A	Cubic Meter
405 (2)	Structural Concrete, Class B	Cubic Meter
405 (3)	Structural Concrete, Class C	Cubic Meter
405 (4)	Structural Concrete, Class P	Cubic Meter
405 (5)	Seal Concrete	Cubic Meter

**DPWH Standard Specification for  
Item 1046 – Masonry Works**

**1046.1 Description**

This Item shall consist of furnishing of all necessary materials, tools, equipment and labor necessary to complete the execution of the masonry works using Concrete Hollow Blocks and Louver Blocks as shown on the Plans and herein specified.

**1046.2 Material Requirements**

**1046.2.1 Hydraulic Cement**

Hydraulic Cement shall conform to the applicable requirements of Item 700, Hydraulic Cement.

**1046.2.2 Aggregates**

Aggregates shall conform to the applicable requirements of Item 405, Structural Concrete.

**1046.2.3 Water**

Water shall conform to the applicable requirements of Item 714, Water.

**1045.2.4 Reinforcing Steel**

Reinforcing steel shall conform to the applicable requirements of Item 710, Reinforcing Steel and Wire Rope.

**1046.2.5 Mortar**

Mortar shall consist of sand, cement and water conforming to the requirements of Item 405, Structural Concrete, mixed in the proportion of one (1) part cement to three parts sand by volume, and sufficient water to obtain the required consistency.

**1046. 2.6 Concrete Hollow Blocks and Louver Blocks**

Width, height and length of concrete hollow blocks and louver blocks shall be  $\pm 3.20\text{mm}$  from the specified dimension shown on the Plans.

**1046.2.6.1 Load-Bearing Concrete Hollow Blocks**

Load-bearing concrete hollow blocks shall conform to the physical requirements of the Tables below as prescribed on ASTM C 90, Standard Specifications for Load-bearing Concrete Masonry Units.

**Table 1046.1 Minimum Thickness of Face Shells and Webs**

Nominal Width (W) of Units, mm	Face Shell Thickness ( $t_s$ ), min., mm	Web Thickness ( $t_w$ )	
		Webs, min., mm	Equivalent Web Thickness, min., mm/linear m
76.2 and 102	19	19	136
152	25	25	188
203	32	25	188
254 and greater	32	29	209

**Table 1046.2 Strength, Absorption, and Density Classification Requirements**

Density Classification	Oven-Dry Density of Concrete, $kg/m^3$	Maximum Water Absorption, $kg/m^3$		Minimum Net Area Compressive Strength, MPa (Psi)	
	Average of 3 Units	Average of 3 Units	Individual Units	Average of 3 Units	Individual Units
Lightweight	Less than 1680	288	320	13.1 (1900)	11.7 (1700)
Medium Weight	1680 to less than 2000	240	272	13.1 (1900)	11.7 (1700)
Normal Weight	2000 or more	208	240	13.1 (1900)	11.7 (1700)

**1046.2.6.2 Non-load bearing Concrete Hollow Blocks and Louver Blocks**

Non-load bearing concrete hollow blocks shall be clearly marked to prevent their use as load bearing units.

- a. **Type I, Moisture-Controlled Units** – Units shall conform to the requirements of Tables 1046.3, 1046.4 and 1046.5.
- b. **Type II, Non-moisture-Controlled Units** – Units designated as Type II shall conform to the requirements of Table 1046.4.

**Table 1046.3 Weight Classification**

Weight Classification	Oven-Dry Density of Concrete, $kg/m^3$
Lightweight	Less than 1680
Medium Weight	1680 to less than 2000
Normal Weight	2000 or more

**Table 1046.4 Strength Requirements**

	Compressive Strength (average net area min.,) MPa (Psi)
Average 3 Units	4.14 (600)
Individual Unit	3.45 (500)

**Table 1046.5 Moisture-Content Requirements for Type I Units**

Total Linear Drying Shrinkage, %	Moisture Content, max, % of Total Absorption (Average of 3 Units)		
	Humidity Conditions at Job Site of Point of Use		
	Humid <sup>B</sup>	Intermediate <sup>C</sup>	Arid <sup>D</sup>
Less than 0.03	45	40	35
0.03 to less than 0.045	40	35	30
0.045 to 0.065, max	35	30	25

Note: <sup>B</sup> Mean annual relative humidity above 75%  
<sup>C</sup> Mean annual relative humidity 50 to 75%  
<sup>D</sup> Mean annual relative humidity less than 50%

### 1046.2.7 Other Constituents

Air-entraining agents, coloring pigments, integral water repellents, finely ground silica, and other constituents, shall be previously established as suitable for use in concrete masonry and shall conform to applicable ASTM standards or shall be shown by test or experience not to be detrimental to the durability of the concrete masonry units or any material customarily used in masonry construction.

### 1046.3 Construction Requirements

#### 1046.3.1 Mixing

Concrete shall be mixed well using the proportion specified by the Engineer. Hand mixing shall be done, using shovels, on a level concrete slab or steel plate. Mix aggregate and cement until the color is uniform. Spread the mixture out, sprinkle water over the surface and mix. Continue with this process until the right amount of water has been mixed in. Mixture shall be free from impurities such as dirt and grass.

If batch mixer is used, accurate timing and measuring devices shall be observed as per manufacturer's recommendation.

#### 1046.3.2 Moulding

Hand operated machines shall be used as manufacturer's recommendation.

The mould of a powered machine should be filled until six (6) to eight (8) cycles of compaction are required to bring the compacting head to its stops.

Demoulding or removal of the mould shall be done carefully so that the fresh blocks are not damaged. Fresh blocks shall be protected from rain with plastic sheets or any suitable covering during the first day and from the drying effects of the sun and wind until curing starts.

#### 1046.3.3 Curing

After being removed from the mold, the Concrete Hollow Blocks (CHB) and Louver Blocks shall be covered with a plastic sheet or tarpaulin and kept damp and shaded for at least seven (7) days in order to effectively cure. This can be achieved by continually spraying them with water or keeping them under water in tanks.

#### **1046.3.4 Installation**

1. All masonry work shall be laid true to line, level, plumb and neat in accordance with the Plans.
2. Units shall be cut accurately to fit all plumbing ducts, opening for electrical works, and all holes shall be neatly patched.
3. No construction support shall be attached to the wall except where specifically permitted by the Engineer.
4. Masonry unit shall be sound, dry, clean and free from cracks when placed in the structure.
5. Proper masonry units shall be used to provide for all window, doors, bond beams, lintels, plasters etc., with a minimum of unit cutting.
6. Where masonry units cutting is necessary, all cuts shall be neat and true to line.
7. Units shall be placed while the mortar is soft and plastic. Any unit disturbed to the extent that the initial bond is broken after initial positioning shall be removed and re-laid in fresh mortar.
8. Mortar should not be spread too far ahead of units, as it will stiffen and lose plasticity, especially in hot weather. Mortar that has stiffened should not be used. ASTM C 270 requires that mortar be used within 2½ hours of initial mixing.

#### **1046.3.5 Reinforcement for Concrete Hollow Blocks**

Reinforcement shall be done in accordance with the structural plans as to size, spacing and other requirements of Item 404 – Reinforcing Steel under Section 404.3 – Construction Requirement.

Reinforcement shall be clean and free from loose, rust, scales and any coatings that will reduce bond.

#### **1046.3.6 Finish and Appearance**

1. All units shall be sound and free of cracks or other defects that interfere with the proper placement of the unit or significantly impair the strength or permanence of the construction. Minor cracks, incidental to the usual method of manufacture or minor chipping resulting from customary methods of handling in shipment and delivery, are not grounds for rejection.
2. Where units are to be used in exposed wall construction, the face or faces that are to be exposed shall not show chips or cracks, not otherwise permitted, or other imperfections when viewed from a distance of not less than 6.1 m under diffused lighting.
  - a. Five percent of a shipment containing chips, not larger than 25.4 mm in any dimension, or cracks not wider than 0.5 mm and not longer than 25% of the nominal height of the unit, is permitted.



3. The color and texture of units shall be specified by the purchaser. The finished surfaces that will be exposed in place shall conform to an approved sample, consisting of not less than four (4) units, representing the range of texture and color permitted.
4. A shipment shall not contain more than 5% of units, including broken unit that do not meet the requirements of the above provisions.

**1046.3.7 Sampling and Testing for Concrete Hollow Blocks and Louvers**

Method of Sampling for Quality Test shall be as follows:

1. One (1) Quality Test for every 10,000 units or fraction thereof.
2. Six (6) specimens to be submitted for one (1) quality test in which three (3) specimens for Compression Test and the remaining three (3) for Moisture Content and Water Absorption.

Units shall be tested in accordance with ASTM C 140, Standard Test Methods for Sampling and Testing Concrete Masonry Units and Related Units and ASTM C 426, Standard Test Method for Linear Drying Shrinkage of Concrete Masonry Units.

**1046.3.8 Storage and Handling of Masonry Works**

The blocks shall be stored in such a way as to avoid contact with moisture at site. They shall be stock-piled on planks or other supports free from contact with ground and covered to protect against wetting. The block shall be handled with care and damaged units shall be rejected.

**1046.4 Method of Measurement**

The work to be paid for under this Item shall be the number of square meters of masonry units that are satisfactorily accepted and completed.

**1046.5 Basis of Payment**

The accepted quantity, measured as prescribed in Section 1046.4, Method of Measurement shall be paid for at the contract unit price for Masonry Works which price and payment shall include the cost of furnishing all labor, materials and equipment necessary to complete the work.

Payment will be made under:

<b>Pay Item Number</b>	<b>Description</b>	<b>Unit of Measurement</b>
1046 (1) a	CHB Load-Bearing (including Reinforcing Steel), 100 mm	Square Meter
1046 (1) b	CHB Non-Load Bearing (including Reinforcing Steel), 150 mm	Square Meter
1046 (2) a	CHB Load-Bearing (including Reinforcing Steel), 100 mm	Square Meter
1046 (2) b	CHB Non-Load Bearing (including Reinforcing Steel), 150 mm	Square Meter
1046 (3)	Louver Block	Square Meter

## ***Section VII. Drawings***

*[Insert here a list of Drawings. The actual Drawings, including site plans, should be attached to this section, or annexed in a separate folder.]*

12009  
A=470

SEE  
SITE DEV. "A"

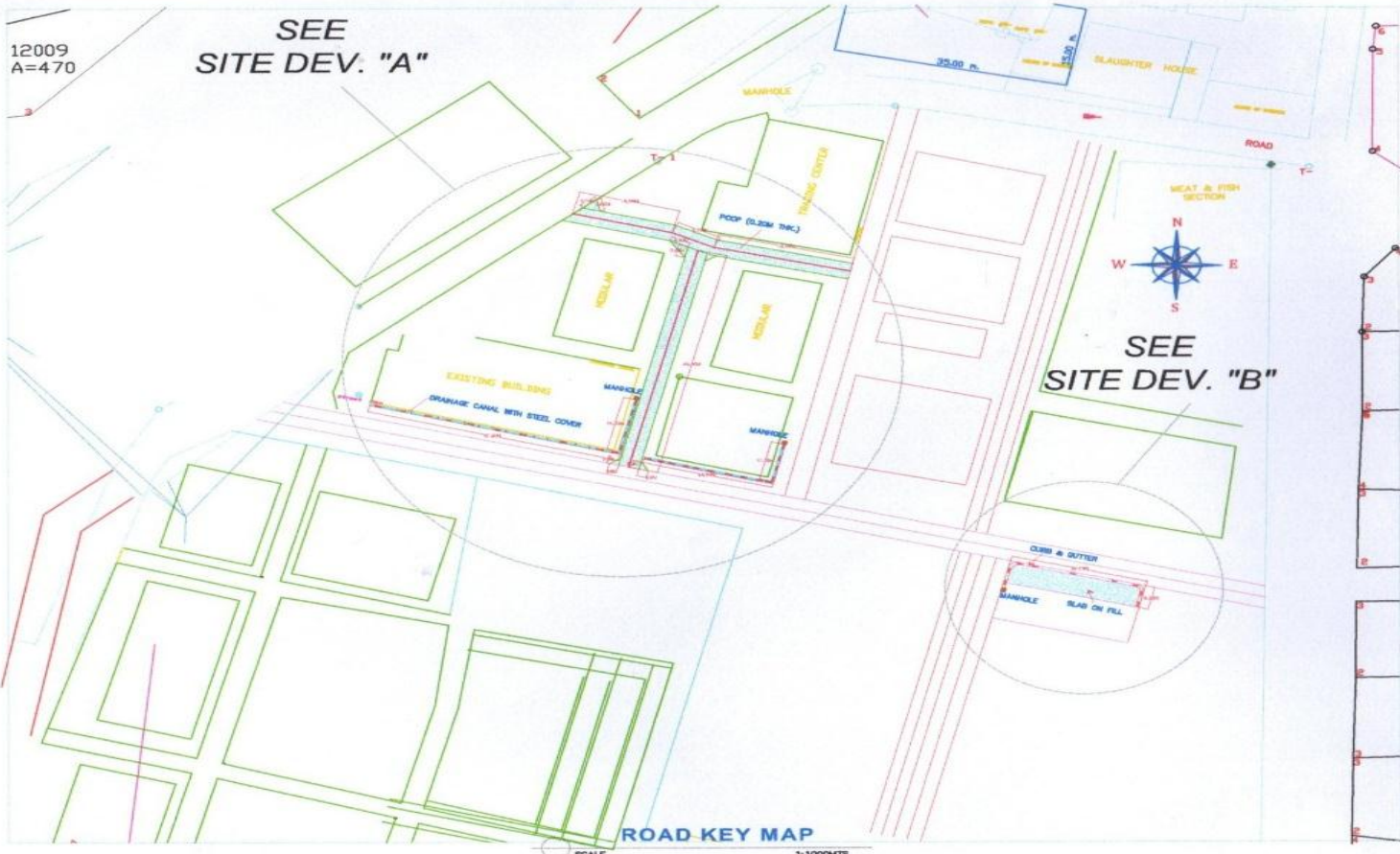

SEE  
SITE DEV. "B"



LOCATION MAP

INDEX SHEETS:

- P1 : ROAD KEY MAP  
LOCATION MAP  
INDEX OF SHEETS
- P2 : GENERAL NOTES (ROADWAY)
- P3 : TYPICAL CROSS SECTIONS  
CONCRETE DRAINAGE DETAIL  
STEEL GRATING COVER DETAIL
- P4 : MANHOLE DETAIL  
TYPICAL DETAIL OF CURB AND GUTTER
- P5 : SITE DEVELOPMENT PLAN "A"
- P6 : SITE DEVELOPMENT PLAN "B"

ROAD KEY MAP

SCALE 1:1000METS



REPUBLIC OF THE PHILIPPINES  
PROVINCE OF DAVAO DE ORO  
MUNICIPALITY OF COMPOSTELA  
OFFICE OF THE MUNICIPAL ENGINEER  
AND BUILDING OFFICIAL

PROJECT TITLE:  
CONCRETING OF BLOCK ROADS  
@ P-1 PUBLIC MARKET  
  
Location:  
PUROK 1, POBLACION,  
COMPOSTELA, DAVA DE ORO

PREPARED BY:  
  
ANTHONY M. VELAZQUEZ  
Instrument Man

CHECKED & REVIEWED BY:  
  
LEONILDO O. CAVAN, CE  
Engineer III

RECOMMENDING APPROVAL:  
  
FELICITA R. DETROS, CE  
Municipal Engineer

APPROVED BY:  
  
LEMA POLETE-BOLO, CPA  
Municipal Mayor

SHEET CONTENTS:  
LOCATION MAP  
ROAD KEY MAP  
INDEX SHEETS

SHEET NO.  
1  
6

**R O A D W A Y**  
**GENERAL NOTES:**

1. ALIGNMENT AND GRADES ARE SUBJECT TO ADJUSTMENTS TO SUIT EXISTING FIELD CONDITIONS.
2. DISTANCES AND ELEVATIONS ARE IN METERS UNLESS OTHERWISE INDICATED.
3. GRADE SHOWN ARE TOP OF FINISHED PAVEMENT ELEVATION.
4. ALL WORK SHALL COMPLY WITH THE "STANDARD SPECIFICATIONS FOR HIGHWAYS & BRIDGES " REVISED 2004.
5. WHERE NO DETOURS ARE AVAILABLE, TRAFFIC SHALL BE HANDLED IN ACCORDANCE WITH THE PROVISIONS OF ARTICLE 7.7 OF THE GENERAL REQUIREMENTS AND COVENANTS.
6. WHERE CLEARING AND GRUBBING IS INDICATED IN THE PLANS OR DIRECTED BY THE ENGINEER. THE AREA TO BE CLEARED FOR SHALL BE THE ROADWAY AREA EXTENDED 1.00 METERS BEYOND THE ROUNDING OF CUT SLOPES, IN CASES WHERE SAID AREA EXTENDS BEYOND THE NORMAL RIGHT-OF-WAY LIMITS. CLEARING AND GRUBBING SHALL BE CONFINED ONLY WITHIN THE LIMITS OF THE ACQUIRED RIGHT-OF-WAY.
7. ALL EMBANKMENT SHALL BE CONSTRUCTED IN ACCORDANCE WITH THE REQUIREMENT OF ITEM 104 (EMBANKMENTS) OF STANDARD SPECIFICATION FOR HIGHWAYS AND BRIDGES, REVISED 2004.
8. CUT SLOPES, EXCEPT IN ROCK, AND FILL SLOPES SHALL BE ROUNDED AT THE TOPS AND BOTTOMS AT INTERSECTIONS OF CUTS AND FILL SLOPES SHALL BE ADJUSTED AND WARPED TO FLOW INTO EACH OTHER OR INTO NATURAL GROUND SURFACE WITHOUT NOTICEABLE BREAK..
9. WATERING AND COMPACTING OF ALL EMBANKMENTS SHALL BE CONSIDERED AS SUBSIDIARY WORK PERTAINING TO OTHER CONTRACT ITEMS. THE COST OF PERFORMANCE THEREOF SHALL BE CONSIDERED TO BE INCLUDED IN THE CONTRACT UNIT PRICE BID FOR THE ITEMS.
10. APPROACHES AND ROAD CONNECTIONS SHALL BE CONSTRUCTED BY THE CONTRACTOR AS SHOWN IN THE PLANS OR AS DIRECTED BY THE ENGINEER IN SUCH MANNER TO ENSURE PROPER CONNECTION TO THE RIDING SURFACES.
11. THE CONTRACTOR SHALL BE CONTINUOUSLY KEEP THE ROAD UNDER GOING IMPROVEMENT AND SECTION DETOURS IN SUCH CONDITION SATISFACTORY TO THE ENGINEER THAT TRAFFIC WILL BE ACCUMULATED DURING THE ENTIRE PERIOD WITHOUT INCONVENIENCE TO THE TRAVELING PUBLIC IN ACCORDANCE WITH ARTICLE 4.6 OF GENERAL REQUIREMENT AND COVENANTS. THE CONTRACTOR SHALL BEAR ALL EXPENSES OF CONSTRUCTING, RECONSTRUCTING IF NECESSARY MAINTAIN SUCH RUN AROUND TEMPORARY BRIDGES WITHOUT DIRECT COMPENSATION.
12. ANY MISCELLANEOUS REMOVAL NOT SHOWN ON THE PLANS INCLUDING REMOVAL OF HEADWALLS AND WINGWALLS OF EXISTING DRAINAGE STRUCTURES THAT ARE TO BE EXTENDED OR APPROVED AND THE DISPOSAL OF RESULTING MATERIALS SHALL BE CONSIDERED AS SUBSIDIARY WORK PERTAINING TO OTHER CONTRACT ITEMS.
13. EXTENSION AND OTHER IMPROVEMENT ON EXISTING DRAINAGE STRUCTURE ARE SUBJECT TO CHANGE AND SHALL BE DETERMINED IN THE FIELD ENGINEER IN-CHARGE.
14. EXACT LOCATIONS, GRADIENTS, LENGTHS, TOP AND INVERT ELEVATIONS OF ALL DRAINAGE STRUCTURES THAT ARE REQUIRED SHALL BE DETERMINED BY THE FIELD ENGINEER.
15. WASTE MATERIALS TO BE DISPOSED APPROXIMATELY 1.0 KM. FROM THE PROJECT LIMIT OR IN OTHER LOCATION AS DESIGNATED BY THE PROJECT ENGINEER.
16. BARRICADES, DANGER SIGNALS AND WARNING SIGNS :  
IN ADDITION TO TRAFFIC SERVICES (ROAD SIGN AND BOLLARDS) PROVIDED IN THE CONTRACT, THE CONTRACTOR SHALL FURNISH ERECTS, AND MAINTAIN AT HIS OWN RISK ALL NECESSARY BARRICADES, SUITABLE AND SUFFICIENT LIGHT, DANGER SIGNALS, SIGNS AND OTHER TRAFFIC CONTROL DEVICES, AND SHALL TAKE ALL NECESSARY PRECAUTIONS FOR THE PROTECTION OF THE WORKS AND SAFETY OF THE PUBLIC THROUGHOUT THE DURATION OF THE PROJECT.

 <p>REPUBLIC OF THE PHILIPPINES PROVINCE OF DAVAO DE ORO MUNICIPALITY OF COMPOSTELA OFFICE OF THE MUNICIPAL ENGINEER AND BUILDING OFFICIAL</p>	<p>PROJECT TITLE: CONCRETING OF BLOCK ROADS @ P-1 PUBLIC MARKET</p>	<p>PREPARED BY:</p>	<p>CHECKED &amp; REVIEWED BY:</p>	<p>APPROVED BY:</p>	<p>SHEET CONTENTS: GENERAL NOTES</p>	<p>SHEET NO. 2 6</p>
	<p>LEONILLO G. CAVAN, CE Engineer III</p>	<p>FELICITA M. DETROS, CE Municipal Engineer</p>	<p>LEMA POBLETE-BOLO, CPA Municipal Mayor</p>			

### TYPICAL ROADWAY SECTION

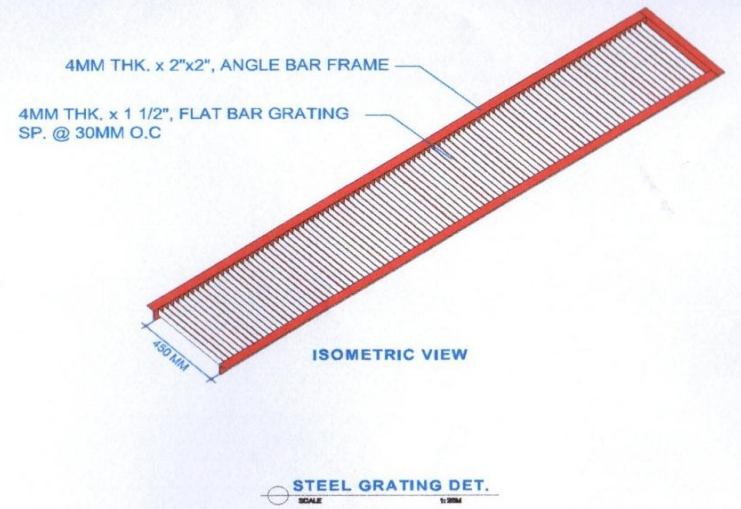
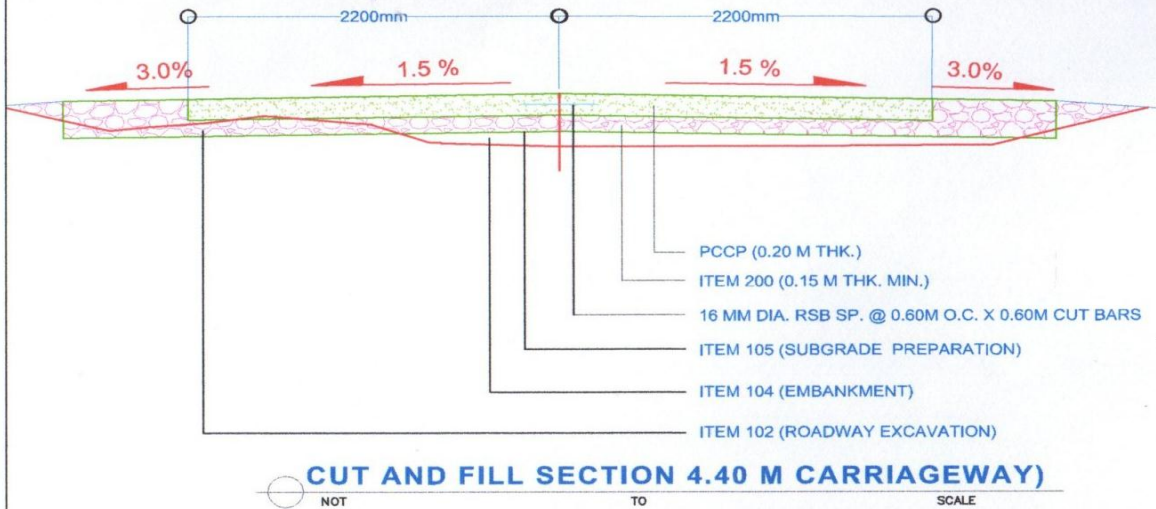

### CONCRETE DRAINAGE DETAIL

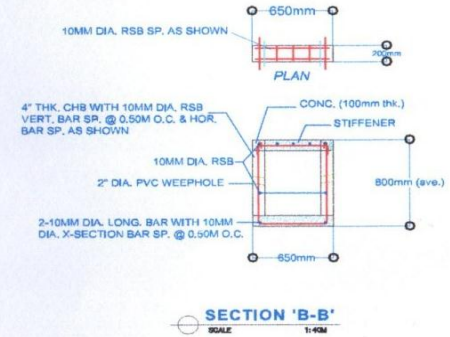
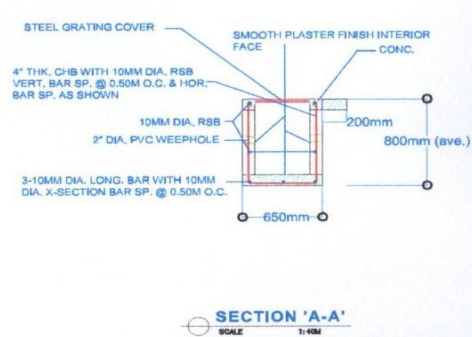
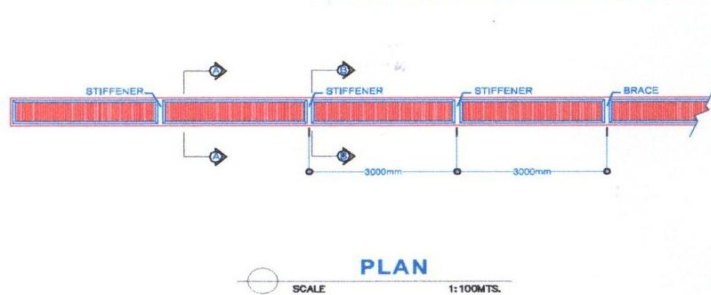

### DETAIL OF CONCRETE DRAINAGE

 <p>REPUBLIC OF THE PHILIPPINES PROVINCE OF DAVAO DE ORO MUNICIPALITY OF COMPOSTELA OFFICE OF THE MUNICIPAL ENGINEER AND BUILDING OFFICIAL AM CY 2020- DILG FUND</p>	<p>PROJECT TITLE: CONCRETING OF BLOCK ROADS @ P-1 PUBLIC MARKET</p>	<p>PREPARED BY: <i>Anthony M. Veloz</i> ANTHONY M. VELOZ Instrument Man</p>	<p>CHECKED &amp; REVIEWED BY: <i>Leonilo D. Cavan</i> LEONILO D. CAVAN, CE Engineer III</p>	<p>RECOMMENDING APPROVAL: <i>Felicita R. Detros</i> FELICITA R. DETROS, CE Municipal Engineer</p>	<p>APPROVED BY: <i>Lema Poblete-Bolo</i> LEMA POBLETE-BOLO, CPA Municipal Mayor</p>	<p>SHEET CONTENTS: TYPICAL CROSS SECTIONS CONCRETE DRAINAGE DETAIL STEEL GRATING COVER DETAIL</p>	<p>SHEET NO. 3 6</p>
	<p>Location: PUROK 1, POBLACION, COMPOSTELA, DAVA DE ORO</p>						

USE 2"X2"X4MM THK. ANGLE BAR FRAME WITH 1 1/2" X 4MM THK. FLAT BAR STEEL GRATING SP @ 30MM O.C.

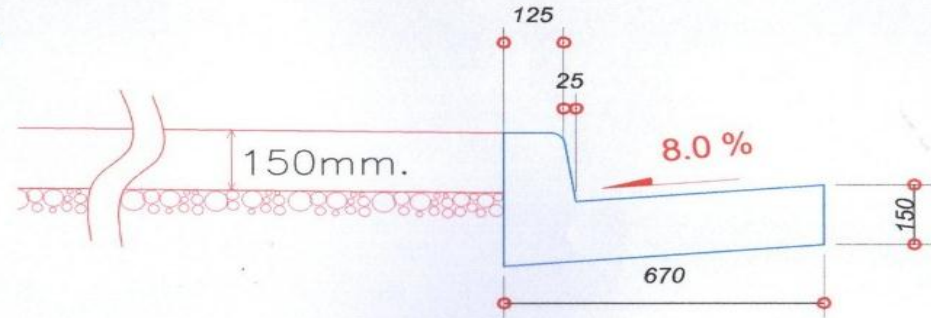
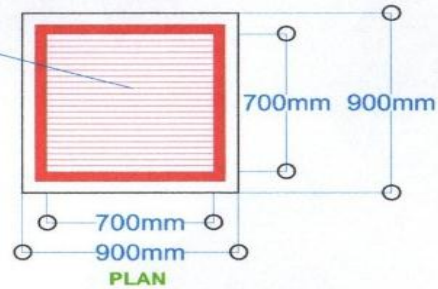

**TYPICAL DETAIL OF CURB AND GUTTER**

SCALE 1:10M

STEEL GRATING COVER

SMOOTH PLASTER FINISH INTERIOR FACE  
CONC.

4" THK. CHB WITH 10MM DIA. RSB  
VERT. BAR SP. @ 0.20M O.C. & HOR.  
BAR SP. AS SHOWN

10MM DIA. RSB

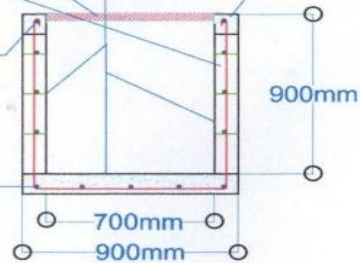

5-10MM DIA. LONG. BAR WITH 10MM  
DIA. X-SECTION BAR SP. @ 0.50M O.C.

**MANHOLE DETAIL**  
SCALE 1:20M



REPUBLIC OF THE PHILIPPINES  
PROVINCE OF DAVAO DE ORO  
MUNICIPALITY OF COMPOSTELA  
OFFICE OF THE MUNICIPAL ENGINEER  
AND BUILDING OFFICIAL

PROJECT TITLE:  
CONCRETING OF BLOCK ROADS  
@ P-1 PUBLIC MARKET

Location:  
PUROK 1, POBLACION,  
COMPOSTELA, DAVA DE ORO

PREPARED BY:  
*Anthony M. Veloz*  
ANTHONY M. VELOZ  
Instrument Man

CHECKED & REVIEWED BY:  
*Leoni O. Cavan*  
LEONILO O. CAVAN, CE  
Engineer III

RECOMMENDING APPROVAL:  
*Felicia R. Detros*  
FELICIA R. DETROS, CE  
Municipal Engineer

APPROVED BY:  
*Lema Poblete-Bolo*  
LEMA POBLETE-BOLO, CPA  
Municipal Mayor

SHEET CONTENTS:  
MANHOLE DETAIL  
TYPICAL DETAIL OF CURB AND GUTTER

SHEET NO.  
4  
6

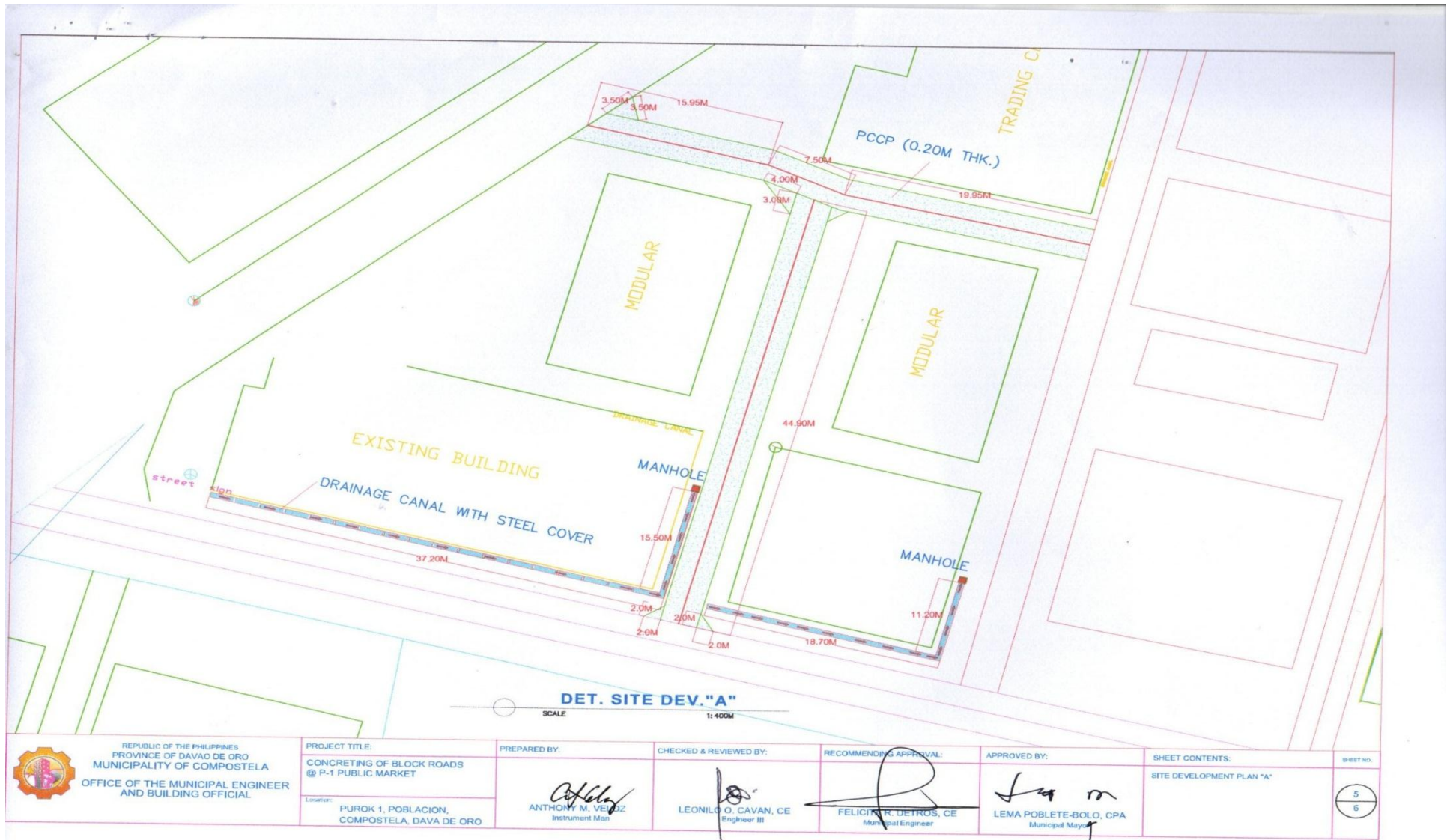

REPUBLIC OF THE PHILIPPINES  
PROVINCE OF DAVAO DE ORO  
MUNICIPALITY OF COMPOSTELA  
OFFICE OF THE MUNICIPAL ENGINEER  
AND BUILDING OFFICIAL

PROJECT TITLE:  
CONCRETING OF BLOCK ROADS  
@ P-1 PUBLIC MARKET  
Location:  
PUROK 1, POBLACION,  
COMPOSTELA, DAVA DE ORO

PREPARED BY:  
*Anthony M. Veloz*  
ANTHONY M. VELOZ  
Instrument Man

CHECKED & REVIEWED BY:  
*Leonilo O. Cavan*  
LEONILO O. CAVAN, CE  
Engineer III

RECOMMENDING APPROVAL:  
*Feliciano R. Detros*  
FELICIANO R. DETROS, CE  
Municipal Engineer

APPROVED BY:  
*Lema Poblete-Bolo*  
LEMA POBLETE-BOLO, CPA  
Municipal Mayor

SHEET CONTENTS:  
SITE DEVELOPMENT PLAN "A"

SHEET NO.  
5  
6

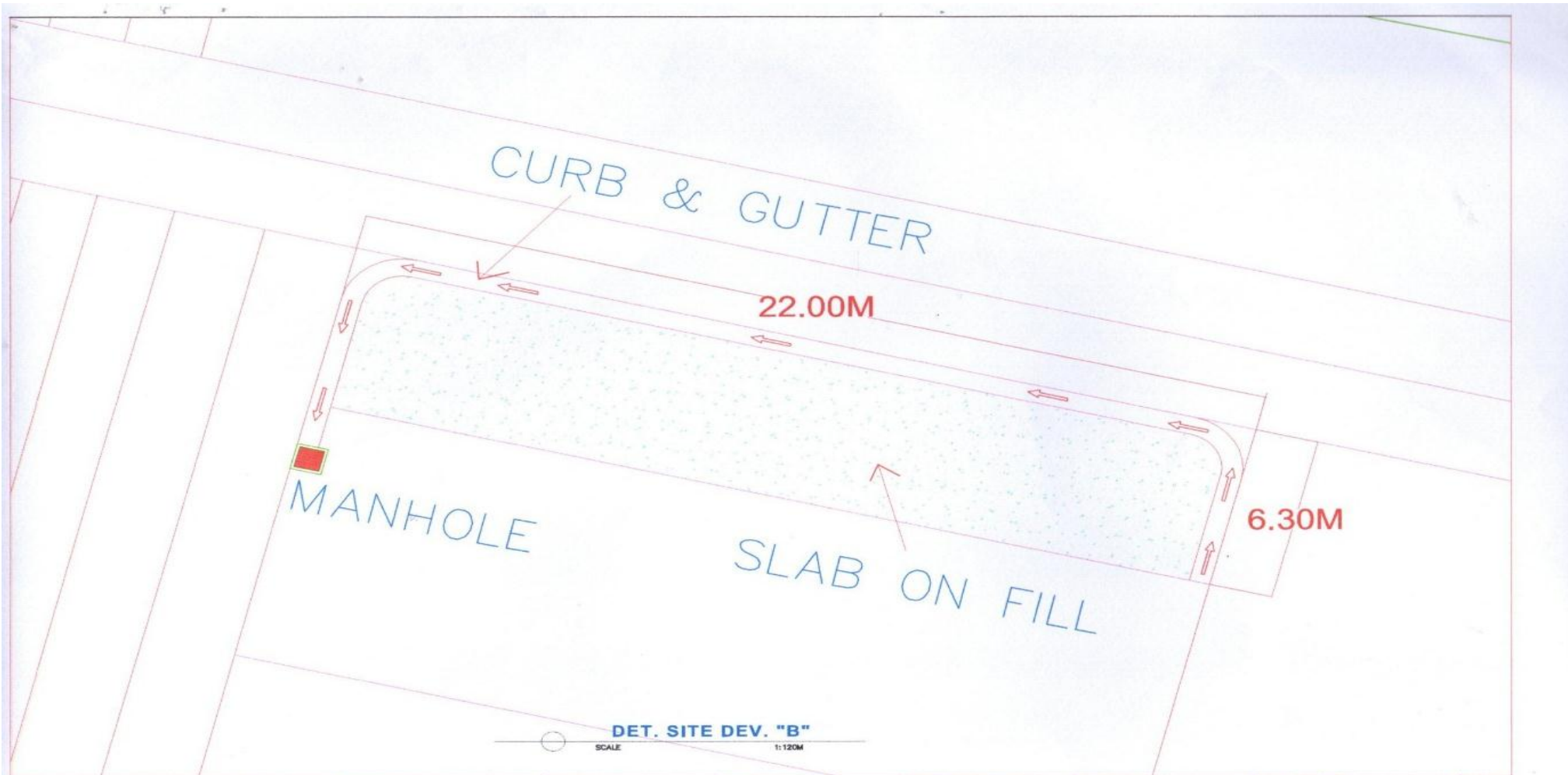

DET. SITE DEV. "B"

SCALE 1:120M

 <p>REPUBLIC OF THE PHILIPPINES PROVINCE OF DAVAO DE ORO MUNICIPALITY OF COMPOSTELA OFFICE OF THE MUNICIPAL ENGINEER AND BUILDING OFFICIAL</p>	<p>PROJECT TITLE: CONCRETING OF BLOCK ROADS @ P-1 PUBLIC MARKET</p>	<p>PREPARED BY: <i>Anthony M. Veloz</i> ANTHONY M. VELOZ Instrument Man</p>	<p>CHECKED &amp; REVIEWED BY: <i>Leoniolo Cavan</i> LEONILOO. CAVAN, CE Engineer III</p>	<p>RECOMMENDING APPROVAL: <i>Felicia R. Detros</i> FELICIA R. DETROS, CE Municipal Engineer</p>	<p>APPROVED BY: <i>Lema Poblete-Bolo</i> LEMA POBLETE-BOLO, CPA Municipal Mayor</p>	<p>SHEET CONTENTS: SITE DEVELOPMENT PLAN "B"</p>	<p>sheet no. 6 6</p>
	<p>Location: PUROK 1, POBLACION, COMPOSTELA, DAVA DE ORO</p>						



## *Section VIII. Bill of Quantities*

**Project Title: *Re-bid: Concreting of Block Roads at P-1 Public Market***  
**ABC (Php): 1,500,000.00**

Project Title: <i>Re-bid: Concreting of Block Roads at P-1 Public Market</i>					
ABC (Php): 1,500,000.00					
Item No.	Description of Works	Quantity	Unit	Unit Price (In words & figures)	Total Price (In words & figures)
1.	SPL-1 MOBILIZATION / DEMOBILIZATION	1	LOT		
2.	102- ROADWAY EXCAVATION	175	CU.M.		
3.	103(1) – STRUCTURE EXCAVATION	46.5	CU.M.		
4.	104 - EMBANKMENT	37	CU.M.		
5.	105 - SUB-GRADE PREPARATION	420	SQ.M.		
6.	200 - AGGREGATES SUBBASE COURSE	62.87	CU.M.		
7.	311- PORTLAND CEMENT CONCRETE PAVEMENT ( PCCP )	419.12	SQ.M.		
8.	403 - FABRICATED STEEL	2,460	KGS.		
9.	404(1) - REINFORCING STEEL BAR, GRADE 40	418.1	KGS.		
10.	405(1) - STRUCTURAL CONCRETE CLASS "A"	29.4	CU.M.		
11.	1046 - MASONRY WORKS	103	SQ.M.		
12.	SPL2 - SIGNAGE & WARNING DEVICE	1	LOT		
<b><i>GRAND TOTAL (In words and Figures)</i></b>					

Note: Total cost of line item includes cost of Contractor's Profit, VAT Tax, others

<hr style="width: 80%; margin: 0 auto;"/> Name of Bidder	<hr style="width: 80%; margin: 0 auto;"/> Authorized Signatory	<hr style="width: 80%; margin: 0 auto;"/> Date
---	---	---

***Section IX. Checklist of Technical and Financial Documents***

# Checklist of Technical and Financial Documents

## I. TECHNICAL COMPONENT ENVELOPE

### *Class “A” Documents*

#### Legal Documents

- (a) Valid PhilGEPS Registration Certificate (Platinum Membership) (all pages);  
**or**
- (b) Registration certificate from Securities and Exchange Commission (SEC), Department of Trade and Industry (DTI) for sole proprietorship, or Cooperative Development Authority (CDA) for cooperatives or its equivalent document;  
**and**
- (c) Mayor’s or Business permit issued by the city or municipality where the principal place of business of the prospective bidder is located, or the equivalent document for Exclusive Economic Zones or Areas;  
**and**
- (e) Tax clearance per E.O. No. 398, s. 2005, as finally reviewed and approved by the Bureau of Internal Revenue (BIR).

#### Technical Documents

- (f) Statement of the prospective bidder of all its ongoing government and private contracts, including contracts awarded but not yet started, if any, whether similar or not similar in nature and complexity to the contract to be bid; **and**
- (g) Statement of the bidder’s Single Largest Completed Contract (SLCC) similar to the contract to be bid, except under conditions provided under the rules; **and**
- (h) Philippine Contractors Accreditation Board (PCAB) License;  
**or**  
Special PCAB License in case of Joint Ventures;  
**and** registration for the type and cost of the contract to be bid; **and**
- (i) Original copy of Bid Security. If in the form of a Surety Bond, submit also a certification issued by the Insurance Commission;  
**or**  
Original copy of Notarized Bid Securing Declaration; **and**
- (j) Project Requirements, which shall include the following:
  - a. Organizational chart for the contract to be bid;
  - b. List of contractor’s key personnel (*e.g.*, Project Manager, Project Engineers, Materials Engineers, and Foremen), to be assigned to the contract to be bid, with their complete qualification and experience data;
  - c. List of contractor’s major equipment units, which are owned, leased, and/or under purchase agreements, supported by proof of ownership or certification of availability of equipment from the equipment lessor/vendor for the duration of the project, as the case may be; **and**
- (k) Original duly signed Omnibus Sworn Statement (OSS);  
**and** if applicable, Original Notarized Secretary’s Certificate in case of a corporation, partnership, or cooperative; or Original Special Power of Attorney of all members of the joint venture giving full power and authority to its officer to sign the OSS and do acts to represent the Bidder.

- (l) Mayor's Permit (Municipality of Compostela)
- (m) Bidder's Fee (Official Receipt)

Financial Documents

- (n) The prospective bidder's audited financial statements, showing, among others, the prospective bidder's total and current assets and liabilities, stamped "received" by the BIR or its duly accredited and authorized institutions, for the preceding calendar year which should not be earlier than two (2) years from the date of bid submission; **and**
- (o) The prospective bidder's computation of Net Financial Contracting Capacity (NFCC).

***Class "B" Documents***

- (p) If applicable, duly signed joint venture agreement (JVA) in accordance with RA No. 4566 and its IRR in case the joint venture is already in existence;  
**or**  
duly notarized statements from all the potential joint venture partners stating that they will enter into and abide by the provisions of the JVA in the instance that the bid is successful.

**II. FINANCIAL COMPONENT ENVELOPE**

- (q) Original of duly signed and accomplished Financial Bid Form; **and**

Other documentary requirements under RA No. 9184

- (r) Original of duly signed Bid Prices in the Bill of Quantities; **and**
- (s) Duly accomplished Detailed Estimates Form, including a summary sheet indicating the unit prices of construction materials, labor rates, and equipment rentals used in coming up with the Bid; **and**
- (t) Cash Flow by Quarter.

# Bidding Forms

## Bid Form for the Procurement of Infrastructure Projects

---

### BID FORM

Date : \_\_\_\_\_

Project Identification No. : \_\_\_\_\_

To: *[name and address of Procuring Entity]*

Having examined the Philippine Bidding Documents (PBDs) including the Supplemental or Bid Bulletin Numbers *[insert numbers]*, the receipt of which is hereby duly acknowledged, we, the undersigned, declare that:

- a. We have no reservation to the PBDs, including the Supplemental or Bid Bulletins, for the Procurement Project: *[insert name of contract]*;
- b. We offer to execute the Works for this Contract in accordance with the PBDs;
- c. The total price of our Bid in words and figures, excluding any discounts offered below is: *[insert information]*;
- d. The discounts offered and the methodology for their application are: *[insert information]*;
- e. The total bid price includes the cost of all taxes, such as, but not limited to: *[specify the applicable taxes, e.g. (i) value added tax (VAT), (ii) income tax, (iii) local taxes, and (iv) other fiscal levies and duties]*, which are itemized herein and reflected in the detailed estimates,
- f. Our Bid shall be valid within the a period stated in the PBDs, and it shall remain binding upon us at any time before the expiration of that period;
- g. If our Bid is accepted, we commit to obtain a Performance Security in the amount of *[insert percentage amount]* percent of the Contract Price for the due performance of the Contract, or a Performance Securing Declaration in lieu of the the allowable forms of Performance Security, subject to the terms and conditions of issued GPPB guidelines for this purpose;
- h. We are not participating, as Bidders, in more than one Bid in this bidding process, other than alternative offers in accordance with the Bidding Documents;
- i. We understand that this Bid, together with your written acceptance thereof included in your notification of award, shall constitute a binding contract between us, until a formal Contract is prepared and executed; and
- j. We understand that you are not bound to accept the Lowest Calculated Bid or any other Bid that you may receive.

- k. We likewise certify/confirm that the undersigned, is the duly authorized representative of the bidder, and granted full power and authority to do, execute and perform any and all acts necessary to participate, submit the bid, and to sign and execute the ensuing contract for the [Name of Project] of the [Name of the Procuring Entity].
- l. We acknowledge that failure to sign each and every page of this Bid Form, including the Bill of Quantities, shall be a ground for the rejection of our bid.

Name: \_\_\_\_\_

Legal Capacity: \_\_\_\_\_

Signature: \_\_\_\_\_

Duly authorized to sign the Bid for and behalf of: \_\_\_\_\_

Date: \_\_\_\_\_

**STATEMENT OF THE BIDDER OF ALL ITS ONGOING GOVERNMENT AND PRIVATE CONTRACTS, INCLUDING CONTRACTS AWARDED BUT NOT YET STARTED**

Business Name: \_\_\_\_\_

Business Address: \_\_\_\_\_

Name of Contract	Date of Contract	Contract Duration	Owner's Name & Address	Nature of Work	Contractor's Role		Total Contract Value at Award	Estimated Completion Time	Estimated Contract Value at Completion	% of Accomplish-ments		Value of Outstanding Works
					Description	% of Participation				Planned	Actual	
<u><b>GOVERNMENT</b></u>												
<u><b>PRIVATE</b></u>												
										<b>TOTAL</b>		

Note: This statement shall be supported with:

1. Notice of Award
2. Contract Agreement

Submitted by: \_\_\_\_\_  
Printed Name and Signature

Designation: \_\_\_\_\_

Date: \_\_\_\_\_



**STATEMENT OF SINGLE LARGEST COMPLETED CONTRACTS (SLCC)**

Business Name: \_\_\_\_\_

Business Address: \_\_\_\_\_

Name of Contract	Date of Contract	Contract Duration	Owner's Name & Address	Nature of Work	Contractor's Role		Total Contract Value at Award	Date of Completion Time	Total Contract Value at Completion
					Description	% of Participation			
<u>Government</u>									
<u>Private</u>									

Note: This statement shall be supported with:

1. Notice of Award and/or Notice to Proceed
2. Contract Agreement
3. Certificate of Final Acceptance or Constructors Performance Evaluation System (CPES) of at least satisfactory rating.

Submitted by: \_\_\_\_\_

Printed Name and Signature

Designation: \_\_\_\_\_

Date: \_\_\_\_\_

## NFCC COMPUTATION

- A. Summary of the Applicant Supplier's/Distributor's/Manufacturer's assets and liabilities on the basis of the attached income tax return and audited financial statement, stamped "RECEIVED" by the Bureau of Internal Revenue or BIR authorized collecting agent, for the immediately preceding year and a certified copy of Schedule of Fixed Assets particularly the list of construction equipment.

		Year 20__
1.	Total Assets	
2.	Current Assets	
3.	Total Liabilities	
4.	Current Liabilities	
5.	Net Worth (1-3)	
6.	Net Working Capital (2- 4)	

- B. The Net Financial Contracting Capacity (NFCC) based on the above data is computed as follows:

NFCC = [(Current Asset – Current Liabilities) (15)] minus value of all outstanding works under ongoing contracts including awarded contracts yet to be started

NFCC = P \_\_\_\_\_

Submitted by:

\_\_\_\_\_  
Name of Supplier / Distributor / Manufacturer

\_\_\_\_\_  
Signature of Authorized Representative

Date : \_\_\_\_\_

## **Bid Securing Declaration Form**

*[shall be submitted with the Bid if bidder opts to provide this form of bid security]*

---

REPUBLIC OF THE PHILIPPINES)  
CITY OF \_\_\_\_\_) S.S.

### **BID SECURING DECLARATION** **Project Identification No.: [Insert number]**

To: *[Insert name and address of the Procuring Entity]*

I/We, the undersigned, declare that:

1. I/We understand that, according to your conditions, bids must be supported by a Bid Security, which may be in the form of a Bid Securing Declaration.
2. I/We accept that: (a) I/we will be automatically disqualified from bidding for any procurement contract with any procuring entity for a period of two (2) years upon receipt of your Blacklisting Order; and, (b) I/we will pay the applicable fine provided under Section 6 of the Guidelines on the Use of Bid Securing Declaration, within fifteen (15) days from receipt of the written demand by the procuring entity for the commission of acts resulting to the enforcement of the bid securing declaration under Sections 23.1(b), 34.2, 40.1 and 69.1, except 69.1(f), of the IRR of RA No. 9184; without prejudice to other legal action the government may undertake.
3. I/We understand that this Bid Securing Declaration shall cease to be valid on the following circumstances:
  - a. Upon expiration of the bid validity period, or any extension thereof pursuant to your request;
  - b. I am/we are declared ineligible or post-disqualified upon receipt of your notice to such effect, and (i) I/we failed to timely file a request for reconsideration or (ii) I/we filed a waiver to avail of said right; and
  - c. I am/we are declared the bidder with the Lowest Calculated Responsive Bid, and I/we have furnished the performance security and signed the Contract.

IN WITNESS WHEREOF, I/We have hereunto set my/our hand/s this \_\_\_\_ day of *[month]* *[year]* at *[place of execution]*.

*[Insert NAME OF BIDDER OR ITS AUTHORIZED  
REPRESENTATIVE]*

*[Insert signatory's legal capacity]*

Affiant

**Jurat**

*[Format shall be based on the latest Rules on Notarial Practice]*

## Omnibus Sworn Statement (Revised)

*[shall be submitted with the Bid]*

---

REPUBLIC OF THE PHILIPPINES )  
CITY/MUNICIPALITY OF \_\_\_\_\_ ) S.S.

### AFFIDAVIT

I, [Name of Affiant], of legal age, [Civil Status], [Nationality], and residing at [Address of Affiant], after having been duly sworn in accordance with law, do hereby depose and state that:

1. *[Select one, delete the other:]*

*[If a sole proprietorship:]* I am the sole proprietor or authorized representative of [Name of Bidder] with office address at [address of Bidder];

*[If a partnership, corporation, cooperative, or joint venture:]* I am the duly authorized and designated representative of [Name of Bidder] with office address at [address of Bidder];

2. *[Select one, delete the other:]*

*[If a sole proprietorship:]* As the owner and sole proprietor, or authorized representative of [Name of Bidder], I have full power and authority to do, execute and perform any and all acts necessary to participate, submit the bid, and to sign and execute the ensuing contract for [Name of the Project] of the [Name of the Procuring Entity], as shown in the attached duly notarized Special Power of Attorney;

*[If a partnership, corporation, cooperative, or joint venture:]* I am granted full power and authority to do, execute and perform any and all acts necessary to participate, submit the bid, and to sign and execute the ensuing contract for [Name of the Project] of the [Name of the Procuring Entity], as shown in the attached [state title of attached document showing proof of authorization (e.g., duly notarized Secretary's Certificate, Board/Partnership Resolution, or Special Power of Attorney, whichever is applicable)];

3. [Name of Bidder] is not "blacklisted" or barred from bidding by the Government of the Philippines or any of its agencies, offices, corporations, or Local Government Units, foreign government/foreign or international financing institution whose blacklisting rules have been recognized by the Government Procurement Policy Board, **by itself or by relation, membership, association, affiliation, or controlling interest with another blacklisted person or entity as defined and provided for in the Uniform Guidelines on Blacklisting;**

4. Each of the documents submitted in satisfaction of the bidding requirements is an authentic copy of the original, complete, and all statements and information provided therein are true and correct;

5. [Name of Bidder] is authorizing the Head of the Procuring Entity or its duly authorized representative(s) to verify all the documents submitted;

6. *[Select one, delete the rest:]*  
*[If a sole proprietorship:]* The owner or sole proprietor is not related to the Head of the Procuring Entity, members of the Bids and Awards Committee (BAC), the Technical Working Group, and the BAC Secretariat, the head of the Project Management Office or the end-user unit, and the project consultants by consanguinity or affinity up to the third civil degree;
- [If a partnership or cooperative:]* None of the officers and members of *[Name of Bidder]* is related to the Head of the Procuring Entity, members of the Bids and Awards Committee (BAC), the Technical Working Group, and the BAC Secretariat, the head of the Project Management Office or the end-user unit, and the project consultants by consanguinity or affinity up to the third civil degree;
- [If a corporation or joint venture:]* None of the officers, directors, and controlling stockholders of *[Name of Bidder]* is related to the Head of the Procuring Entity, members of the Bids and Awards Committee (BAC), the Technical Working Group, and the BAC Secretariat, the head of the Project Management Office or the end-user unit, and the project consultants by consanguinity or affinity up to the third civil degree;
7. *[Name of Bidder]* complies with existing labor laws and standards; and
8. *[Name of Bidder]* is aware of and has undertaken the responsibilities as a Bidder in compliance with the Philippine Bidding Documents, which includes:
- a. Carefully examining all of the Bidding Documents;
  - b. Acknowledging all conditions, local or otherwise, affecting the implementation of the Contract;
  - c. Making an estimate of the facilities available and needed for the contract to be bid, if any; and
  - d. Inquiring or securing Supplemental/Bid Bulletin(s) issued for the *[Name of the Project]*.
9. *[Name of Bidder]* did not give or pay directly or indirectly, any commission, amount, fee, or any form of consideration, pecuniary or otherwise, to any person or official, personnel or representative of the government in relation to any procurement project or activity.
- 10. In case advance payment was made or given, failure to perform or deliver any of the obligations and undertakings in the contract shall be sufficient grounds to constitute criminal liability for Swindling (Estafa) or the commission of fraud with unfaithfulness or abuse of confidence through misappropriating or converting any payment received by a person or entity under an obligation involving the duty to deliver certain goods or services, to the prejudice of the public and the government of the Philippines pursuant to Article 315 of Act No. 3815 s. 1930, as amended, or the Revised Penal Code.**

**IN WITNESS WHEREOF**, I have hereunto set my hand this \_\_ day of \_\_, 20\_\_ at \_\_\_\_\_, Philippines.

*[Insert NAME OF BIDDER OR ITS AUTHORIZED REPRESENTATIVE]*

*[Insert signatory's legal capacity]*

Affiant

**[Jurat]**

*[Format shall be based on the latest Rules on Notarial Practice]*

